

INTERNATIONAL BOXING ASSOCIATION

Technical & Competition Rules

Effective from March 24, 2011

(Latest amendments: March 27, 2012)



AMENDMENTS

(Effective from March 27, 2012)

The following amendments to the AIBA Technical & Competition Rules were approved by the AIBA Executive Committee Bureau on March 27, 2012 and are effective immediately:

RULES FOR COMPETITION MANAGEMENT

Rule 4.	Medical Examination (Rule 4.4. and Rule 4.5.)	10
---------	--	----

APPENDIXES

Appendix D	World Ranking Guidelines (reference to Women Boxers has been added) (reference to Olympic Qualifying Events has been removed)	48
Appendix E	Seeding Procedure for the Draw Ceremony (reference to Women Boxers has been added)	50
Appendix N	Declaration of Non-Pregnancy (new)	84

All above amendments are underlined in the present document.

TABLE OF CONTENTS

DEFINITIONS	5
RULES FOR COMPETITION MANAGEMENT	6
Rule 1. Classification of Boxers	7
Rule 2. Eligibility of Boxers.....	6
Rule 3. Registration of Boxers for Competitions	10
Rule 4. Medical Examination.....	10
Rule 5. Weigh-In	11
Rule 6. Substitution of Boxers at General Weigh-In	11
Rule 7. Official Draw	12
Rule 8. Duration and Number of Rounds	12
Rule 9. Decisions	13
Rule 10. AIBA Scoring System	15
Rule 11. Scoring Points.....	15
Rule 12. Fouls	16
Rule 13. Boxer “Down“	17
Rule 14. AIBA Competition Approval	18
Rule 15. Competition Venue	18
Rule 16. AIBA Anti-Doping Regulations	19
RULES FOR COMPETITION OFFICIALS	20
Rule 1. Technical Delegate (TD).....	20
Rule 2. Deputy Technical Delegate (DTD)	20
Rule 3. Competition Manager (CM)	21
Rule 4. International Technical Official (ITO)	21
Rule 5. Competition Jury & Judges’ Evaluator	22
Rule 6. Rules for Both Referees & Judges	23
Rule 7. Referees	24
Rule 8. Judges	25
Rule 9. AIBA Referees & Judges Management.....	26
Rule 10. Coaches.....	26
Rule 11. AIBA Coaches Management	26
Rule 12. Seconds.....	26
Rule 13. Medical Jury	28
Rule 14. Timekeeper.....	29
Rule 15. Official Announcer	30
RULES FOR COMPETITION EQUIPMENT	31
Rule 1. Use of AIBA Licensee Equipment.....	31
Rule 2. Ring and Accessories.....	31
Rule 3. Gloves.....	31
Rule 4. Headguards	31
Rule 5. Bandages.....	32
Rule 6. Gumshield.....	32
Rule 7. Protectors	32
Rule 8. Competition Uniform.....	33
Rule 9. AIBA Scoring System Equipment	33

TABLE OF CONTENTS

APPENDIX A: Duties of and Guidelines for Competition Officials.....	34
APPENDIX B: AIBA Code of Conduct.....	45
APPENDIX C: AIBA Approved Event Guidelines	46
APPENDIX D: World Ranking Guidelines	48
APPENDIX E: Seeding Procedure for the Draw Ceremony.....	50
APPENDIX F: Boxers' Uniform Guidelines	56
APPENDIX G: AIBA Referees & Judges (R&J) Management System.....	59
APPENDIX H: Ring Specifications and Guidelines.....	67
APPENDIX I: Field of Play (FOP) Management.....	70
APPENDIX J: Glove and Headguard Specifications and Guidelines	74
APPENDIX K: Terminology for Weight Categories and Weight Range.....	77
APPENDIX L: AIBA Scoring System	78
APPENDIX M: AIBA Coaches Management System	81
APPENDIX N: Declaration of Non-Pregnancy	84

COMPLIANCE TO THE RULES

These AIBA Technical & Competition Rules are the only Technical & Competition Rules worldwide which AIBA National Member Federations, boxing members, clubs and family must follow and respect in any of their competitions in accordance to activities at all levels. No National Federation may develop its own Technical & Competition Rules that are contradictory to the AIBA Technical & Competition Rules.

DEFINITIONS

“**AIBA**” means the International Boxing Association;

“**AIBA Controlled Events**” means AIBA Approved Events solely managed by AIBA as described in Appendix C;

“**AIBA Approved Events**” means boxing competitions which are approved and/or endorsed by AIBA. AIBA allows the use of its logo and provides AIBA Officials to manage these events as described in Appendix C;

“**Bout**” means a boxing match;

“**Confederation**” means a group of National Federations recognized by AIBA belonging to the same continent;

“**Daily Weigh-In**” means that each entered Boxer is required to weigh-in each day on which this Boxer is due to box to ensure that the actual weight on that day does not exceed the maximum of the Boxer's registered weight class;

“**Delegation**” means participating Team Members including Boxers, Coaches, Team Doctors and Team Managers in any competition;

“**Draw Commission**” means a group of minimum two persons who will draw the R&Js for each bout in any competition;

“**Dual Match**” means a competition featuring Boxers from two countries only;

“**Field of Play (FOP)**” means the competition area which extends for at least 6 meters outside the platform of the ring;

“**Gloves**” means equipment that you wear on your hands in order to protect them during the competition;

“**Headguard**” means equipment that you wear on your head in order to protect it during the competition;

“**ITO**” means the International Technical Officials appointed by AIBA excluding R&Js such as the Competition Jury, the Draw Commission and the Medical Jury members, the R&J Coordinator and the Equipment Manager;

“**Judge**” means someone who allocates points during a bout based on each Boxer's performance on the ring in respect of the AIBA Technical & Competition Rules;

“**National Federation**” means any Federation that is admitted into membership of AIBA by the Congress, hence becoming a Member of AIBA;

“**Official Draw**” means the ceremony to draw the Boxers to decide the bout schedules in each weight category;

“**Participating Boxer**” means any Boxer licensed by a National Federation that is a Member of AIBA; the term Boxer refers to Boxers of both genders;

“**Referee**” means someone ensuring that the AIBA Technical & Competition Rules are followed by the Boxers during their bouts;

“**Team Officials**” mean the Team Managers, Coaches and Doctors of a team entered by a National Federation in any competition excluding Boxers;

“**Technical Delegate**” means a person who is appointed by AIBA or by a Confederation to be responsible for all technical related issues in any competition;

“**WSB**” means the boxing competition named World Series of Boxing solely recognized as an AIBA Approved Event.

RULES FOR COMPETITION MANAGEMENT

RULE 1. CLASSIFICATION OF BOXERS

1.1. Age Classification

- 1.1.1. Men and Women Boxers between the ages of 19 - 34 are categorized as Elite Boxers.
- 1.1.2. Boys and Girls Boxers between the ages of 17 to 18 are categorized as Youth Boxers.
 - 1.1.2.1. Youth Boxers are permitted to participate in Elite Boxers' competitions as per Rules applicable to Elite Boxers.
- 1.1.3. Boys and Girls Boxers between the ages of 15 to 16 are categorized as Junior Boxers.
- 1.1.4. The age of a Boxer is determined using his/her year of birth.
- 1.1.5. All competitions related to school age boys and girls as well as all other younger age Boxers are managed only at National Federation and at Confederation levels. The age of the Boxers shall not be over 14 years old. The range of the ages of the Boxers participating in these competitions shall not be more than 2 years.

1.2. Weight Classification¹

- 1.2.1. For Elite Men and Youth Boxers (Boys):
 - 1.2.1.1. Ten (10) Weight Categories as follow:
46 kg - 49 kg, 52 kg, 56 kg, 60 kg, 64 kg, 69 kg, 75 kg, 81 kg, 91 kg, 91+ kg.
- 1.2.2. For Elite Women and Youth Boxers (Girls):
 - 1.2.2.1. Ten (10) Weight Categories as follow:
45 kg - 48 kg, 51 kg, 54 kg, 57 kg, 60 kg, 64 kg, 69 kg, 75 kg, 81 kg, 81+ kg
 - 1.2.2.2. For Elite Women, 3 Weight Categories for the Olympic Games as follow:
48 kg to 51 kg, 57 kg to 60 kg, 69 kg to 75 kg
- 1.2.3. For Junior Boxers (Boys and Girls):
 - 1.2.3.1. Thirteen (13) Weight Categories as follow:
44 kg - 46 kg, 48 kg, 50 kg, 52 kg, 54 kg, 57 kg, 60 kg, 63 kg, 66 kg, 70 kg,
75 kg, 80 kg and 80+ kg.

¹Terminology for each Weight Category can be found in Appendix K.

RULE 2. ELIGIBILITY OF BOXERS

2.1. Nationality

- 2.1.1. Any Boxer participating in AIBA Approved Events must be a national of the country of the AIBA National Federation participating in such competitions.
- 2.1.2. For all disputes taking place during World Championships, Olympic Games, World Cup, President's Cup and any other AIBA and Confederation approved level event, the final decision on determining the nationality lies with the AIBA Executive Committee.
- 2.1.3. If a Boxer wishes to change nationality, this Boxer can enter any AIBA Approved Event as a participant of the changed National Federation after three (3) years from the change of Boxer's nationality.
- 2.1.4. If a Boxer, after having represented one National Federation in any AIBA Approved Event, is also a national of two or more countries simultaneously, this Boxer shall select only one National Federation to enter AIBA Approved Events. In this case, once the Boxer selects one National Federation, this Boxer shall not enter any AIBA Approved Event as a participant of the changed National Federation for three (3) years.
- 2.1.5. For the determination of the three (3) years period, AIBA shall develop a database of all Boxers to trace their competition records. Any Host Federation and Organizing Committee should be able to send the final entries to AIBA in order to receive a confirmation on the nationality and eligibility status of any Boxer prior to any competition. However, until the database is completed, the nationality shall be checked through the passport, Boxer's Competition Record Book and/or membership card and/or any previous AIBA Approved Event result.
- 2.1.6. Prior to the competition, the AIBA HQs Office shall confirm the nationality and eligibility of the Boxer. However, during the competition, any dispute will be resolved by the Technical Delegate and then will be ratified by the AIBA HQs Office.

2.2. One Entry per Weight Category

- 2.2.1. For all boxing competitions including AIBA Controlled and Approved Events such as World Championships, Olympic Games, World Cup, President's Cup, Continental Championships, Olympic Qualifying Events and Confederation Controlled and Approved Events, only one Boxer per Weight Category per country shall be allowed to compete.

2.3. Medical Aspects of Qualification for Boxers

2.3.1. Medical Certification

- 2.3.1.1. A Boxer shall not be allowed to compete in an international competition unless such Boxer possesses a valid up to date International Competition Record Book in which such Boxer must be certified as fit to box by a qualified Medical Doctor as approved by the presiding AIBA Medical Jury Member.
 - 2.3.1.1.1. A Medical Doctor shall not be considered to be qualified as such unless he/she provides clear and legible proof of identity and medical credentials.

- 2.3.1.1.2. In order for an Annual Medical Examination to be valid, the examination must have been (i) completed by a Qualified Medical Doctor, (ii) no later than 12 months before the date of the relevant competition and (iii) the record of the examination must contain clearly legible results for all test areas as well as (iv) must be uploaded to any online or offline registration for international competitions.
- 2.3.1.2. On each day a Boxer will be required to box, this Boxer shall be certified as fit to compete by a Qualified Medical Doctor who shall be approved by the National Federation under whose jurisdiction the competition is taking place, or during the Olympic Games, World Championships, World Cup, President's Cup and AIBA Challenge Matches, by the AIBA Medical Commission.
- 2.3.1.3. A Boxer should respect a minimum rest period of 12 hours between two (2) bouts.
- 2.3.2. Boxer with Allowed Handicap
- 2.3.2.1. Refer to current AIBA Medical Handbook for allowed handicaps.
- 2.3.3. Prohibited Conditions - The Boxers with the following prohibited conditions are not allowed to enter any AIBA Approved Event:
- 2.3.3.1. If a Boxer wears a dressing on a cut, wound abrasion, laceration or blood swelling on the scalp or face including the nose and ears. For the case of a Boxer with abrasion or laceration, no dressing other than Collodion or Steri-Strip is allowed. The decision should be made by the Doctor examining the Boxer on the day the Boxer is competing.
- 2.3.3.2. A Boxer shall be clean-shaved before all Medical Examinations. Beards and moustaches are not allowed. No type of body piercing and no body accessories are permitted to be worn during a bout.
- 2.3.3.3. No Boxer with an implanted device which uses electricity or any substance which may alter bodily function shall be permitted to box.
- 2.3.3.4. Refer to current AIBA Medical Handbook for other prohibited conditions.
- 2.3.4. Medical Certification following Probation Periods - Before resuming boxing after any of the periods of rest prescribed in the three Rules 2.3.6.1, 2.3.6.2, 2.3.6.3, a Boxer must be certified by the Boxer's Physician to be able to take part in competitive boxing.
- 2.3.5. Referee Stop Contest – Head Blow (RSCH) – The Referee will indicate to the Competition Jury members and Judges to annotate the score with "RSCH" when the Referee has stopped the contest as a result of a Boxer being unable to continue due to blows to the head. 'RSCH' is a term to be used only when a Boxer is being saved from a Knock-Out after having received hard head blows making the Boxer defenseless and incapable of continuing (the term RSCH is not to be used when a Boxer is simply outclassed and is receiving too many scoring hits without scoring).
- 2.3.6. Protective Sanitary Measures
- 2.3.6.1. One Knock-Out or RSCH - A Boxer who has been knocked out or given an RSCH decision as a result of head blows during a contest or wherein the Referee has stopped the contest due to the Boxer having received hard blows to the head making this Boxer defenseless or incapable of continuing, shall not be permitted to take part in competitive boxing or sparring for a period of at least 30 days after the Boxer has been knocked out or given an RSCH decision.

- 2.3.6.2. Two Knock-Outs or two RSCH - A Boxer who has been knocked out as a result of head blows during a contest or wherein the Referee has stopped the contest due to a Boxer having received hard blows to the head making this Boxer defenseless or incapable of continuing twice in a period of 90 days, shall not be permitted to take part in competitive boxing or sparring during a period of 90 days from the second Knock-Out or RSCH.
- 2.3.6.3. Three Knock-Outs or three RSCH - A Boxer who has been knocked out as a result of head blows during a contest or wherein the Referee has stopped the contest due to the Boxer having received hard blows to the head making this Boxer defenseless or incapable of continuing three times in a period of 12 months, shall not be allowed to take part in competitive boxing or sparring for a period of 360 days from the third Knock-Out or RSCH.
- 2.3.6.4. Each Knock-Out suffered as a result of a head blow and each RSCH must be recorded by the Medical Jury in the Boxer's International Competition Record Book.
- 2.3.6.5. If a Boxer has been knocked out or received a severe head blow which results in a bout being terminated, the Ringside Doctor will classify the seriousness of the concussion and prescribe the medical restriction period as follows:
 - 2.3.6.5.1. In the event of no Lost of Consciousness (LOC), a minimum restriction of 30 days
 - 2.3.6.5.2. In the event of LOC for less than one (1) minute, a minimum restriction of 90 days
 - 2.3.6.5.3. in the event of LOC more than one (1) minute, a minimum restriction of 180 days
 - 2.3.6.5.4. Any Boxer who suffers a second LOC within three (3) months of resuming boxing after a first LOC will have the previous medical restriction doubled
 - 2.3.6.5.5. Any Boxer who suffers three (3) LOCs within 12 months will be suspended for a minimum of 360 days from the date of the third LOC
 - 2.3.6.5.6. Any Boxer who has a medical restriction must not train or spar during the restricted period.
- 2.3.6.6. All protective measures should also apply if a Knock-Out and/or concussion occurs during training or anywhere else. The Coach shall be responsible to report to the National Federation.
- 2.3.6.7. If one Boxer is knocked-out by a blow after "break" or "stop" and is counted "out", the win by disqualification does not permit this Boxer to continue boxing in the competition.
- 2.3.6.8. Injured Boxers may be restricted from boxing at the discretion of the Medical Jury.
- 2.3.6.9. Boxers returning from RSCH – Knock-Out injuries must receive clearance in writing from their national medical commission and inform the AIBA HQs Office before returning to box.
 - 2.3.6.9.1. If the country does not have any national medical commission, the clearance should be required from the AIBA Medical Commission.

2.4. Eligibility of WSB and Non-AIBA Boxers

- 2.4.1. All WSB Boxers shall be allowed to participate in the Olympic Games and Olympic Qualifying Events at all levels as well as to designated important events.

- 2.4.2 All Boxers who have also been involved in any professional boxing or any other professional combat sport than boxing shall not be permitted to compete in any AIBA and/or WSB competition at any level.
- 2.4.3 Any Boxer who enters into a contract, memorandum of understanding, pre-agreement or any other form of agreement, with an entity or individual other than AIBA (or any entity that is an affiliate or subsidiary of AIBA), related to such Boxer's future participation in professional boxing or any other professional combat sport than boxing, shall not be eligible to participate in any AIBA Approved or Controlled Event at any level including, for the avoidance of doubt, the Olympic Games.

RULE 3. REGISTRATION OF BOXERS FOR COMPETITIONS

3.1. Validity of Documents

The following are mandatory documents and material that any Boxer entering any AIBA Approved Event must possess:

- 3.1.1. Passport - The nationality and date of birth of the Boxer will be checked.
- 3.1.2. Boxer's Competition Record Book - The authenticity of Boxer's update of medical and membership status will be checked.
- 3.1.3. Accreditation Card - The Boxer should prove his/her registered status in a competition by presenting a valid accreditation card.

RULE 4. MEDICAL EXAMINATION

- 4.1. At the time fixed for the Weigh-In, the Boxer must be considered as fit to compete and examined by a Medical Doctor appointed by a member of the Medical Jury before being weighed-in. With a view to ensure a smooth running of the Weigh-In, the Technical Delegate may decide to begin the Medical Examination at an earlier time. The Chairperson of the Medical Jury can select local or Team Doctors to assist with the duties of the Medical Jury only for the Medical Examination.
- 4.2. At the Medical Examination and Weigh-In, an up-to-date Competition Record Book with correct information must be presented by the Boxer. This Competition Record Book must be signed and/or stamped by the Secretary General or Executive Director of the Boxer's National Federation, where the requisite entries shall be made by the Officials in charge. If a Competition Record Book is not presented by the Boxer at the Medical Examination and Weigh-In, this Boxer shall not be allowed to compete.
- 4.3. Gender Test - For AIBA Approved Events, a gender test can be done.
- 4.4. At the document check point before the Medical Examination:
- Every Woman Boxer aged 18 (eighteen) or older must sign a declaration provided by the Medical Jury certifying that she is not pregnant at that time.
 - Every Girl Boxer aged under 18 (eighteen) at the start of the relevant event must provide a declaration signed by:
 - 1) herself
 - 2) and by one of her parents/legal caretakercertifying that she is not pregnant at that time. It shall be the responsibility of National Federations' Team Officials to ensure that Girls Boxers under 18 (eighteen) on their respective team bring such declaration to the relevant event.

- 4.5. Girls and Women Boxers who fail to sign/ provide the declaration of non-pregnancy shall not be allowed to participate in the relevant event (see Appendix N for the forms on the declaration to be signed).

RULE 5. WEIGH-IN

5.1. In AIBA Approved Events

- 5.1.1. All entered Boxers must attend the General Weigh-In in the morning of the first competition day, except as described in article 5.1.2.
- 5.1.2. In AIBA Approved Events, when the number of entered Boxers exceeds 300 after the final entry deadline is closed and for the Olympic Games, the General Weigh-In may be organized no more than 24 hours prior to the Medical Examination of the first competition day based on the Technical Delegate's decision.
- 5.1.3. In any case, the time from the end of the General Weigh-In to the start of the first bout should not be less than 6 hours. The time from the end of the Daily Weigh-In to the start of the first bout of the remaining days of competition should not be less than 3 hours.
- The Technical Delegate reserves the right to relax this condition, if unavoidable circumstances occur and after consultation with the Chairperson of the Medical Jury.
- 5.1.4. The Weigh-In shall be conducted by Officials authorized by the Technical Delegate. A Team Official of the National Federation of the Boxer may be present at the Weigh-In; however, and in any circumstance, the Team Official is not allowed to interfere in the process of Weigh-In.
- 5.1.5. For the General Weigh-In, the registered Boxer's weight should not exceed the maximum of the Boxer's weight class nor be below the minimum of the Boxer's weight class which will also apply to the Daily Weigh-In. The weight registered at the General Weigh-In on the first day decides the Boxer's weight class for the entire competition, but this Boxer will still be required to weigh-in each day on which this Boxer is due to box in order to ensure that the actual weight on that day does not exceed the maximum of the Boxer's registered weight class.
- 5.1.6. Scale - The weight is the one shown on the scale, the body being naked except for a swimming suit or underwear. When necessary, the Boxer may take off the underwear on the scale only. Electronic scales may be used. Trial scales used at the tournament and official Weigh-In scales have to be of the same manufacturer and of the same calibration.
- 5.1.7. The Weigh-In must be conducted by Officials of the same gender.

RULE 6. SUBSTITUTION OF BOXERS AT GENERAL WEIGH-IN

- 6.1. A Boxer will be allowed to be present at the official scales only once at the first Medical Examination and General Weigh-In. The weight recorded on that presentation is final.
- 6.2. If the General Weigh-In is not yet closed, it is permissible, however, for the Team Official of the National Federation of any Boyer who has failed to make it into the Weight Category at the General Weigh-In, to enter this Boxer thereupon for the higher or lower Weight Category for which this Boxer is qualified if such National Federation has a free place in that Weight Category, and the General Weigh-In is not yet closed.
- 6.3. It is also permissible for a National Federation to substitute one Boxer for another at any time up to the close of the Medical Examination and General Weigh-In provided that in any competition where reserves are permitted, the substitute Boxer has been entered as reserve for that Weight Category, or any other Weight Category.
- 6.4. This rule is only applicable for open Championships where reserved Boxers are permitted.
- 6.5. All other cases of substitution shall be finalized the day before the General Weigh-In.

RULE 7. OFFICIAL DRAW

- 7.1. The Official Draw shall take place as soon as possible after the Medical Examination and General Weigh-In. It shall be completed no less than three (3) hours prior to the first bout on the first day of the competition.
- 7.2. The Official Draw shall not be held more than 3 hours after the completion of the General Weigh-In at the exception of Rule 7.3., and if the General Weigh-In is organized the morning prior to the first competition day. At least one Team Official of each participating Delegation must attend the Official Draw.
- 7.3. However, subjected to Rule 5.1.2., the Official Draw shall be held one day before the competition.
- 7.4. A computerized draw system is to be used in all AIBA Approved Events, except for the Olympic Games and World Championships where a manual draw may be conducted. In case the computerized draw system is not working, a manual system can be used.
- 7.5. Possible Re-Draw - In any case, until the last Weight Category draw is completed, if there is any mistake or unavoidable circumstance taking place, the Technical Delegate has the right to order that Weight Category draw to be done again.
- 7.6. Byes - In the event there are more than two Boxers, a sufficient number of byes shall be drawn in the first series in order to reduce the number of Boxers in the second series to 2, 4, 8, 16 or 32.

Boxers drawing a bye in the first series shall box in the second series, but in the order in which they were drawn.
- 7.7. The Technical Delegate must ensure, where applicable, that no Boxer shall box twice in the competition before all other Boxers of the same Weight Category have boxed at least once. In special situations, the Technical Delegate has the right to relax this rule.
- 7.8. Bout Schedule - At the Olympic Games, World Championships and Continental Championships, the bout schedule should be arranged in the order of weights so that in each series, the lightest weights will be run off first and thereafter in order of weights up to the heaviest weights in that series followed by the lightest weights in the next series, and so on. In arranging the schedule of the Semi-Finals and Finals of these Events, the wishes of the Organizing Committee may be accommodated by the Technical Delegate, as long as the results of the draw are not called into question.
- 7.9. Seeding Procedure – It shall respect the seeding procedure for the Draw Ceremony (i.e. Appendix E) and be in accordance with the World Ranking Guidelines (i.e. Appendix D).

RULE 8. DURATION AND NUMBER OF ROUNDS

- 8.1. In all AIBA Elite Men and Youth Boys competitions, the bouts shall consist of three (3) rounds of three (3) minutes each.
- 8.2. In all AIBA Elite Women and Youth Girls competitions, the bouts shall consist of four (4) rounds of two (2) minutes each.
- 8.3. In all AIBA Junior Boys and Girls competitions, the bouts shall consist of three (3) rounds of two (2) minutes each.
- 8.4. For all above listed events, the rest time between rounds is one (1) minute.

RULE 9. DECISIONS

9.1. Win on Points

9.1.1. The winner on points will be the Boxer who has the highest Total Score at the end of the bout as described in Appendix L.

9.2. Win by Retirement

9.2.1. If a Boxer retires voluntarily due to an injury, or if a towel is thrown in the ring by a Second, or if the Boxer fails to resume boxing immediately after the rest between rounds, the opponent shall be declared the winner.

9.3. Win by Referee Stopping Contest (RSC)

9.3.1. Outclassed - RSC is a term used to stop a bout when a Boxer is outclassed or is unfit to continue. If a Boxer, in the opinion of the Referee, is being outclassed or is receiving excessive punishment, the bout shall be stopped and the opponent shall be declared the winner.

9.3.2. RSC Injury

9.3.2.1. If a Boxer, in the opinion of the Referee/Doctor, is unfit to continue because of injury sustained from correct blows or other action or is incapacitated for any other physical reason, the bout shall be stopped and the opponent declared the winner by RSC. In the case where Boxers are injured at the same time, the Boxer with the higher score shall be declared the winner.

9.3.2.2. The right to make this decision rests with the Referee who may consult with the Medical Jury.

9.3.2.3. When a Referee calls a Doctor into the ring to examine a Boxer, only these two Officials should be present. No other person should be allowed into the ring or on the apron.

9.4. Win by RSCH

9.4.1. If a Boxer is unfit to continue and fails to resume boxing after this Boxer has received hard blows to the head, the opponent shall be declared the winner by RSCH.

9.5. Win by Disqualification

9.5.1. If a Boxer is disqualified before any bout starts, the opponent of the disqualified Boxer shall be declared the winner.

9.5.2. In case a Boxer is disqualified after winning the 1st bout in the preliminaries, the opponent who lost against the disqualified Boxer has the right to return into the competition only in case the next bout has not started.

9.5.3. A Boxer disqualified for any unethical behavior or disciplinary matters shall not be entitled to any prize, medal, trophy, honorable award, or grading, relating to any stage of the competition in which this Boxer has been disqualified and the misconduct should be reported to the Disciplinary Commission.

9.6. Win by Knock-Out

9.6.1. If a Boxer is "down" and fails to resume boxing after this Boxer is counted out to ten, the opponent shall be declared the winner by Knock-Out.

9.7. "No Contest"

9.7.1. A bout may be terminated by the Referee inside the scheduled distance owing to some material happening outside the responsibility of the Boxers, or the control of the Referee, such as the ring becoming damaged, the failure of the lighting supply, exceptional weather conditions, etc. In such circumstances, the bout shall be declared "No Contest" and in the case of Championships, the Technical Delegate shall decide the necessary further action.

9.8. Win by Walk-Over

9.8.1. When a Boxer is present in the ring fully attired for boxing and this Boxer's opponent fails to appear after having been called out by the public address system, the bell has sounded and a maximum period of one minute has elapsed, the Referee shall declare the first Boxer to be the winner by Walk-Over. The Referee shall first inform the Competition Jury and then shall summon the Boxer to the center of the ring and after the decision is announced, raise this Boxer's hand as the winner.

9.8.1.1 No medal shall be awarded to a Boxer who has not boxed at least once within the entire competition period.

9.9. Decision in Case of a Draw

9.9.1. The procedure of the decision in case of a draw is described in Appendix L.

9.9.2. The final winner in each weight category shall be nominated in all AIBA Approved Events.

9.9.3. A draw decision may be awarded only in Dual Matches. Likewise, an injury in the first round may result in a draw in Dual Matches.

9.10. Incidents in the Ring outside the Control of the Referee

9.10.1. If something happens that does not allow the bout to continue within one minute after the bell has rung for the beginning of the first, second, or third round (in case of 4 round bouts), e.g. power failure, the bout shall be stopped and the Boxers will box again in the last bout of the same session.

9.10.2. If the incident occurs in the last round of a bout, the contest shall be terminated and the Judges are asked to give a decision as to the winner of the bout.

9.10.3. If the bout cannot be resumed to box at the end of the same session, it will be moved to the beginning of the next session before the original schedule. If the next session is on the following day, the Boxers shall be weighed and medically examined again for the bout.

9.10.4. If bouts must be stopped and can be resumed, the score will be recorded and taken over to the time to resume the bout.

9.11. Protests

9.11.1. A protest shall be submitted by the Team Leader or by the person having the highest position in the Team Delegation no later than 30 minutes after the completion of the bout. Any protest shall be against the decision(s) of the Referee and/or Judges of the bout.

9.11.2. The protest shall be made in writing and handed to the Chairperson of the Competition Jury specifying definitive and clear reasons for the protest.

9.11.3. The protest fee is US\$ 500. An administrative fee of US\$ 100 will be deducted from this amount and the remaining amount will be refunded if the protest is upheld. If the protest is rejected, the entire fee will not be returned to the protester.

9.11.4. The Chairperson of the Competition Jury has the right to refuse the protest(s). In the case where the protest is accepted by the Chairperson of the Competition Jury, the evaluation shall be conducted only by members of the Competition Jury involved in the bout and immediately after the session is completed. The Chairperson of the Competition Jury shall inform the result of the evaluation and report to the Technical Delegate immediately. The Technical Delegate will immediately inform both Team Leaders verbally and thereafter in writing but no later than the Weigh-In and Medical Examination of the next day.

9.11.5. A video recording of the protested bout(s) will be used to analyze the bout(s) in all AIBA Approved Events.

9.11.6. A protest during the Finals of a competition should be notified within 5 minutes of completion of the bout.

9.11.7. In the case of a protest during the Finals of a competition, the Award Ceremony will be postponed until the results of the evaluation are announced.

RULE 10. AIBA SCORING SYSTEM

10.1. The AIBA Scoring System shall be used in competitions at all levels including all AIBA and Confederation Approved Events and National Events.

10.2. In case the AIBA Scoring System is being used, no Judges' score sheets shall be kept. All information required for making up decisions is recorded by the computer and, at the end of the contest, printed out automatically.

10.3. If the AIBA Scoring System becomes defective, the procedure shall be as follows:

The Chairperson of the Competition Jury shall stop the bout for one (1) minute. If, during that period the system cannot be repaired, the score at the time of the breakdown will be saved and the five (5) Judges shall use handheld scoring devices and record the bout for the rest of its duration on scoring paper. At the end of the contest, the Chairperson of the Competition Jury shall collect the scoring paper from the five (5) Judges, add on the scores from the AIBA Scoring System up to the breakdown and, after examination by the Competition Jury, the winner should be announced accordingly. If the AIBA Scoring System cannot be repaired, then the Competition Jury can decide to continue the session / competition allowing the Judges to score the bouts with handheld scoring devices and bout scoring paper.

10.4. In all AIBA Approved Events and the Olympic Games, the AIBA Scoring System shall be operated by persons selected by AIBA and the use of an electronic scoring machine is compulsory.

10.5. In all AIBA Controlled Events, the review camera is a mandatory integral part of the AIBA Scoring System.

10.6. Display of Scores

The spectators and corners will be able to see the scores on a screen; however, the Referee, the five Judges and the Medical Jury should not be able to see the scores during the bout.

10.6.1. In all AIBA Approved Events and the Olympic Games, the use of a public display system is compulsory.

RULE 11. SCORING POINTS

11.1. Valid Scoring Points

11.1.1. During each round, a Judge shall assess the respective scores of each Boxer according to the number of scoring blows obtained. Each blow, to have a scoring value, must, without being blocked or guarded, land directly with the knuckle part of the closed glove of either hand on any part of the front or sides of the head or body above the belt. Swings landing as above described are scoring blows.

11.1.2. The awarding of a point shall follow the principle of one point for every correct blow.

11.2. Non-Valid Scoring Point

11.2.1. No extra point shall be awarded for a Knock-Down.

RULE 12. FOULS

12.1. Type of Fouls

- 12.1.1. Hits below the belt, hitting, tripping, kicking, pulling & hitting and butting with foot or knee.
- 12.1.2. Hits or blows with head, shoulder, forearm, elbow, throttling of the opponent and pressing with arm or elbow in the opponent's face, pressing the head of the opponent back over the ropes.
- 12.1.3. Hits with an open glove, the inside of the glove, wrist or side of the hand.
- 12.1.4. Hits landing on the back of the opponent, especially any blow on the back of the neck or head and kidney punch.
- 12.1.5. Pivot blows.
- 12.1.6. Attack whilst holding the ropes or making any unfair use of the ropes.
- 12.1.7. Lying on, wrestling and throwing in the clinch.
- 12.1.8. An attack on the opponent who is "down" or who is in the act of rising.
- 12.1.9. Holding or locking of the opponent's arm or head, or pushing an arm underneath the arm of an opponent.
- 12.1.10. Ducking below the belt of the opponent in a manner dangerous to the opponent.
- 12.1.11. Completely double passive defense and intentionally falling, running, or turning the back to avoid a blow.
- 12.1.12. Inappropriate, aggressive, or offensive utterances during the round.
- 12.1.13. Not stepping back when ordered to break.
- 12.1.14. Attempting to strike the opponent immediately after the Referee has ordered "break" and before taking a step back.
- 12.1.15. Assaulting or behaving in an aggressive manner towards a Referee at any time.
- 12.1.16. Spitting out gumshield (teeth protector).
- 12.1.17. Keeping the advanced hand straight in order to obstruct the opponent's vision.

12.2. Cautions, Warnings, Disqualifications

- 12.2.1. The Boxer who does not obey the instructions of the Referee, acts against the rules of boxing, boxes in any unsportsmanlike manner, or commits fouls, can, at the discretion of the Referee, be cautioned, warned or disqualified. If a Referee intends to warn a Boxer, he/she shall stop the contest, and demonstrate the infringement. The Referee will then point to the Boxer and to each of the five Judges. A Referee having once administered a warning for a particular foul, i.e. holding, cannot issue a caution for the same type of offence. A third caution for the same type of foul will mandatorily require a warning to be issued. Only three warnings may be given to the same Boxer in one contest. The third warning brings automatic disqualification.

12.3. When a Boxer receives a warning by the Referee which the majority number of Judges concurs was warranted, then the warned Boxer's opponent will have two (2) points added to the score by the Judges pressing the appropriate button on the pad of the AIBA Scoring System.

- 12.3.1. However, in case of a tie, these points shall not apply in the draw calculation (see Appendix L - Rule 4.2.1.).

- 12.4. If the Referee has any reason to believe that a foul has been committed which the Referee has not seen, the Referee may consult the Judges.
- 12.5. Boxers shall shake hands before the beginning and after a bout. Any further shaking of hands during the bout is prohibited.
- 12.6. If a Boxer's gumshield falls down for the first time, a caution will be given by the Referee. Thereafter, every time the gumshield falls down, a warning will be issued. In the case where the gumshield is out of the Boxer's mouth, the Referee shall take the Boxer to the Boxer's corner, have the gumshield washed and returned to its proper position. While this is being done, the Second is not allowed to talk to the Boxer.
- 12.7. If the Boxer intentionally spits out his/her gumshield, an immediate warning shall be issued.

RULE 13. BOXER DOWN

13.1. Definition of "Down"

- 13.1.1. If the Boxer touches the floor with any part of the body other than the Boxer's feet as the result of a blow or series of blows.
- 13.1.2. If the Boxer hangs helplessly on the ropes as the result of a blow or series of blows.
- 13.1.3. If the Boxer is outside or partly outside the ropes as the result of a blow or series of blows.
- 13.1.4. If following a hard punch the Boxer has not fallen and is not lying on the ropes, but is in a semi-conscious state and cannot, in the opinion of the Referee, continue the bout.

13.2. Counts during "Down"

- 13.2.1. In the case of a Knock-Down, the Referee shall immediately begin to count the seconds. When a Boxer is "down", the Referee shall count from one to eight if the Boxer is ready and count from one to ten if the Boxer is continuously down with intervals of a second between the numbers, and shall indicate each second with the fingers in such a manner that the Boxer who has been knocked down may be aware of the count.

Before the number "one" is counted, an interval of one second must have elapsed from the time when the Boxer is knocked down.

If the opponent does not go to the neutral corner on the command of the Referee, the Referee shall stop counting until the opponent has done so. The counting shall then be continued from where it had been interrupted.

13.3. Opponent's Responsibilities

- 13.3.1. If a Boxer is "down", the Boxer's opponent must at once go to the neutral corner as designated by the Referee.

13.4. Mandatory Eight Count

- 13.4.1. When a Boxer is "down" as the result of a blow, the bout shall not be continued until the Referee has reached the count of eight, even if the Boxer is ready to continue before then.

13.5. The Knock-Out

- 13.5.1. After the Referee has said "ten" and the word "out", the bout ends and shall be decided as a Knock-Out.

13.6. Boxer "Down" at the End of Round

- 13.6.1. In the event of a Boxer being “down” at the end of any round, the Referee shall continue to count. Should the Referee count up to ten, such Boxer shall be deemed to have lost the bout by a Knock-Out.
- 13.7. Second Time Boxer “Down” without a Fresh Blow
- 13.7.1. If a Boxer is “down” as the result of a blow and the bout is continued after the count of eight has been reached, but the Boxer falls again without having received a fresh blow, the Referee shall continue the counting from the count of eight before the Referee stopped.
- 13.8. Both Boxers “Down”
- 13.8.1. If both Boxers go “down” at the same time, counting will be continued as long as one of them is still “down”. If both Boxers remain “down” until ten, the bout will be stopped and both Boxers will lose by Knock-Out.
- 13.8.2. If this occurs in the Semi-Finals or Finals, the Boxer with the higher score at the time of the “down” will be the winner.
- 13.9. Compulsory Count Limits
- 13.9.1. At the Elite level, when a Boxer has three (3) compulsory counts in the same round or four (4) for the whole bout, the Referee shall stop the contest (RSC or RSCH).
- 13.9.2. At all other levels, a bout shall be stopped after two (2) compulsory counts in the same round or three (3) for the whole bout.
- 13.9.3. A “down” or count caused by any foul shall not be included in the compulsory count limit.

RULE 14. AIBA COMPETITION APPROVAL

- 14.1. Conditions for an AIBA Competition Approval can be found in the AIBA Approved Event Guidelines (Appendix C).

RULE 15. COMPETITION VENUE

15.1. Field of Play (FOP)

- 15.1.1. The AIBA official formation of the Field of Play in case of one (1) or two (2) rings can be found in Appendix I.

15.2. Required Venue Facilities

In addition to setting up the ring(s), the Organizing Committee should prepare the following venue facilities and rooms:

- 15.2.1. Waiting Lounge for Referees & Judges.
- 15.2.2. Boxers’ Locker Rooms.
- 15.2.3. Anti-Doping Rooms.
- 15.2.4. Medical-Check Room (Doctor’s Room).

- 15.2.5. Boxers' Warm-Up Room.
 - 15.2.6. Storage for Boxing Equipment.
 - 15.2.7. Offices for AIBA, Organizing Committee, Technical Delegate
 - 15.2.8. Media/Press Room, Interview/Press Conference Room, Mixed Zone in accordance with the AIBA Media/Press Guidelines
 - 15.2.9. Meeting Room for ITOs and Referees & Judges
 - 15.2.10. VIP Lounge.
- 15.3. Additional Venue Requirements
- 15.3.1. The organizers of mixed events where both men and women compete shall arrange for separate rooms where the Medical Examinations and Weigh-Ins may be carried out separately for men and women.
 - 15.3.2. Medical Examination of Women Boxers shall be carried out according to the AIBA Medical Handbook.

RULE 16. AIBA ANTI-DOPING REGULATIONS

- 16.1. All issues related to Anti-Doping are to be found in the AIBA Anti-Doping Rules.

RULES FOR COMPETITION OFFICIALS

RULE 1. TECHNICAL DELEGATE (TD)

1.1. Qualifications

- 1.1.1. The Technical Delegate must exhibit superior leadership and management skills by having passed the AIBA Technical Delegate examination and obtained the certificate.
- 1.1.2. Active Coaches, Referees, Judges, Team Managers and any person with an over six (6) month suspension record cannot be appointed as Technical Delegate.

1.2. Nomination & Appointment

- 1.2.1. For all AIBA Approved Events, the AIBA Technical & Rules Commission nominates the candidates and the AIBA President approves, appoints and dismisses the Technical Delegate who must be from a different country than the one where the event takes place.
- 1.2.2. For all Continental Championships, the Confederation Competition Commission nominates the candidates and the Confederation President approves, appoints and dismisses the Technical Delegate who must be from a different country than the one where the event takes place.

1.3. Duties

- 1.3.1. The detailed duties of the Technical Delegate are listed in Appendix A.

RULE 2. DEPUTY TECHNICAL DELEGATE (DTD)

2.1. Appointment

- 2.1.1. For all AIBA events where the number of entered Boxers exceeds 500, after the final entry deadline is closed, and for the Olympic Games, AIBA may appoint a Deputy Technical Delegate.

2.2. Qualifications

- 2.2.1. The Deputy Technical Delegate must exhibit superior leadership and management skills by having passed the AIBA Technical Delegate examination and obtained the certificate. The Deputy Technical Delegate can replace the Technical Delegate if he/she is absent.
- 2.2.2. Active Coaches, Referees, Judges, Team Managers and any person with an over six (6) month suspension record cannot be appointed as Deputy Technical Delegate.
- 2.2.3. The Deputy Technical Delegate must be from a different country than the one where the event takes place.

2.3. Duties

- 2.3.1. The detailed duties of the Deputy Technical Delegate are listed in Appendix A.

RULE 3. COMPETITION MANAGER (CM)

- 3.1. The Competition Manager must be nominated by the Host National Federation and approved by the Confederation or AIBA depending if it is a Confederation Approved Event or an AIBA Approved Event.
- 3.2. The Competition Manager is responsible for following the instructions and guidance of the Technical Delegate to perform the duties that are attached in Appendix I.
- 3.3. The Competition Manager shall have an excellent level of spoken English.

RULE 4. INTERNATIONAL TECHNICAL OFFICIAL (ITO)

4.1. Qualifications

- 4.1.1 Each ITO must obtain the AIBA ITO certification.
- 4.1.2. Active Coaches, Referees, Judges, Team Managers and any person with an over six (6) month suspension record cannot be appointed as ITO.

4.2. Definition

All Officials working within the Field of Play (FOP) excluding the Technical Delegate(s), the Referees & Judges and the Organizing Committee staff are called ITOs. ITOs consist of the following persons:

- 4.2.1. Competition Jury Members and Judges' Evaluator(s).
- 4.2.2. Draw Commission Members.
- 4.2.3. Medical Jury Members.
- 4.2.4. Equipment Manager.
- 4.2.5. R&J Coordinator.
- 4.2.6. Other assigned positions by the Technical Delegate to work inside the FOP.

4.3. Nomination & Appointment

- 4.3.1. AIBA Executive Committee members, Chairpersons of AIBA Commissions, Technical & Rules Commission members, Refereeing & Judging Commission members and Medical Commission members are the main candidates for an ITO appointment.
- 4.3.2. For all AIBA Approved Events, the Technical Delegate nominates the candidates and the AIBA President approves, appoints and dismisses the ITOs.
- 4.3.3. For all Continental Championships, the Technical Delegate nominates the candidates and the Confederation President approves, appoints and dismisses the ITOs.
- 4.3.4. ITOs shall not be more than two members from the same nationality in the same event as long as these ITOs from the same nationality are not assigned in the same bout.
- 4.3.5. The Host National Federation shall not send any ITO for its hosting event, except eventually the person(s) who is(are) appointed as Judges' Evaluator(s).

RULE 5. COMPETITION JURY & JUDGES' EVALUATOR

5.1. Appointment

- 5.1.1. For the Olympic Games and World Championships, the Competition Jury shall be composed of AIBA Executive Committee and Technical & Rules Commission members who have a record of having been registered on the International List of Referees & Judges in the past together with members of the AIBA Refereeing & Judging Commission.
- 5.1.2. For Continental Championships, the Competition Jury shall be composed of members of the Confederation Executive Committee who have a record of having been registered on the International List of Referees & Judges in the past together with the members of the Confederation Refereeing & Judging Commission.

5.2. Composition of Members in Competition

- 5.2.1. For each boxing session (other than the Finals), the Competition Jury shall consist of 3 persons according to Rule 4.2.1 of which one is the Chairperson.

5.3. Position and Rotation of Members in Competition

- 5.3.1. No one other than members of the Competition Jury shall sit at the Jury's table during sessions. The rotation of the Competition Jury members for each session shall be arranged prior to the start of the competition by the Technical Delegate. Members wishing to change places on the rotation must first obtain the consent of the Technical Delegate.

5.4. Procedure of making Decisions

- 5.4.1. The Chairperson of the Competition Jury shall announce all decisions on behalf of all Jury members.

5.5. Duties

- 5.5.1. The Chairperson of the Competition Jury shall make the announcer aware of the name of the Boxer shown as the winner on the computer monitor after the bout is over.
- 5.5.2. The Competition Jury members should watch the scores and performances of the Referees & Judges and immediately suspend any wrongdoing Referee & Judge for the rest of the competition day. Then, once the competition is completed, the Technical Delegate and three (3) Competition Jury members shall discuss any further recommendations to the Disciplinary Commission regarding sanctioning the Referee & Judge.
- 5.5.3. If an Official appointed for a contest is absent, the Chairperson of the Competition Jury may appoint a suitable member from the roll of approved Officials to replace the absent member, reporting this change to the Technical Delegate immediately.
- 5.5.4. If circumstances should arise which would militate against the holding of a contest under proper conditions and if the Referee does not take efficient action concerning the situation, the Chairperson of the Competition Jury may order boxing to cease until it may be satisfactorily resumed.
- 5.5.5. The Chairperson of the Competition Jury may also take any immediate action as may deemed necessary to deal with circumstances that would militate against the proper conduct of boxing at any session.
- 5.5.6. Should the Boxer be guilty of a serious and deliberate offence that is contrary to the spirit of sportsmanship, the Chairperson of the Competition Jury, the Referee, the Competition Jury members, the Technical Delegate and ITOs have the right to recommend to the Executive Committee Bureau to put the case to the Disciplinary Commission for possible sanctions.

- 5.5.7. The Competition Jury members may not act as such in bouts involving Boxers from their own countries.
- 5.5.8. The Chairman of the Competition Jury and/or the Technical Delegate shall be responsible for cautioning, warning and/or removing Seconds with the support of the other two (2) Competition Jury Members.
- 5.5.9. The detailed duties of the Competition Jury are listed in Appendix A.
- 5.6. Overruling the Referee
 - 5.6.1. A decision of a Referee may be overruled by the Chairperson of the Competition Jury when the Referee has given a decision which is clearly against the presently stated Rules and the AIBA Statutes and Bylaws. When considering such an incident, the Competition Jury may use a video tape recording of the incident.
- 5.7. The Chairperson of the Competition Jury shall conduct the Referees & Judges' pre-session Meeting.
- 5.8. Judges' Evaluator
 - 5.8.1. For all AIBA Approved Events, one (1) Judges' Evaluator per ring shall be appointed. The Judges' Evaluator shall be appointed as an ITO from any country regardless of the location of the events.
 - 5.8.2. For all AIBA Controlled Events, one (1) Judges' Evaluator per ring shall be appointed. To qualify for this position, persons must have an AIBA International Level R&J or an AIBA 3-Star Level Coach background, or have an AIBA Technical Delegate Level certification. These persons must have passed the AIBA R&J Instructor Course.
 - 5.8.3. The Judges' Evaluator shall compare the individual scores and performances of the Judges while watching the bouts in order to evaluate the judging abilities of each appointed Judge.

Judges' Evaluators shall not evaluate Judges from their own countries.

RULE 6. RULES FOR BOTH REFEREES & JUDGES

6.1. Designation and Neutrality

To ensure neutrality, the names of the Referee and of the five Judges for each contest shall be selected by a Computerized Software Program and/or a Draw Commission.

- 6.1.1. Each of such Officials shall be an approved Referee & Judge.
- 6.1.2. Each of such Referee & Judge shall be of a different country and Federation from one another and from each of the Boxers taking part in the contest.
- 6.1.3. Each of such Referee & Judge shall not be a national of or resident in any country which is a dominion, colony or dependency of the country of any of the Boxers taking part in the contest.
- 6.1.4. In the event of a change of nationality, such Referee & Judge shall not officiate in any contest in which a Boxer of the Referee & Judge's former nationality is taking part.
- 6.1.5. In the case the Draw Commission cannot apply the above directives, the difficulty shall be resolved by ensuring as far as it may be possible the neutrality and impartiality of the Officials appointed, and shall report the matter as soon as convenient to the Technical Delegate.
- 6.1.6. In the event it is impossible for the Draw Commission to comply with the above directives, the Technical Delegate will make the final selection.

6.2. Conflict of Interest

- 6.2.1. Referees & Judges in any contest or series of contests shall not at any time during the same contest or series of contests act as Team Manager, Coach or Second to any Boxer or team of Boxers taking part in such contest or series of contests or so act in a contest in which a Boxer of their nationality is taking part.

6.3. Disciplinary Action

- 6.3.1. A decision on suspension related to Referees or Judges' poor performances at the event shall be made by the Technical Delegate with the evaluation of the Competition Jury.
- 6.3.2. A decision on suspension related to Referees or Judges' ethics shall be made by the Disciplinary Commission.

6.4. Code of Conduct

- 6.4.1. All Referees & Judges should respect and sign the AIBA Code of Conduct (Appendix B).

RULE 7. REFEREES

7.1. Designation and Participation

- 7.1.1. In the Olympic Games and all AIBA Approved Events, each contest shall be controlled by an AIBA approved Referee who shall officiate on the ring and shall not score the bout.

7.2. Duties

- 7.2.1. The care of the Boxer should be the primary concern of the Referee.
- 7.2.2. Rules and fair-play should be strictly observed.
- 7.2.3. Control of the contest should be maintained at all its stages.
- 7.2.4. A weak Boxer should be prevented from receiving undue and unnecessary punishment.
- 7.2.5. Three (3) words of command should be used:
 - 7.2.5.1. "Stop" when ordering the Boxers to stop boxing
 - 7.2.5.2. "Box" when ordering the Boxers to continue boxing
 - 7.2.5.3. "Break" to stop a clinch, upon which command each Boxer shall step back before continuing boxing.
- 7.2.6. Indicate to a Boxer by suitable explanatory signs or gestures any infringement of the present Rules.
- 7.2.7. In case of one or both Boxers are deaf, the Referee can use a touch by hand on the shoulder or on the arm to "stop" and to "break" the bout.
- 7.2.8. The Referee shall not indicate the winner by raising a Boxer's hand or otherwise, until the announcement has been made. When the winner of a bout is announced, the Referee shall raise the hand of the winning Boxer.

- 7.2.9. When the Referee has disqualified a Boxer or stopped the bout, the Referee shall first inform the Chairperson of the Competition Jury which Boxer has been disqualified or the reason for which the bout was stopped, to enable the Chairperson of the Competition Jury to instruct the Announcer to make the decision correctly known to the public.
- 7.2.10. Obligation - A Referee should be physically fit to perform the duties in the ring after passing a Medical Examination before the competition.
- 7.3. Authorities of the Referee
- 7.3.1. To terminate a contest at any stage if the Referee considers it to be one-sided.
- 7.3.2. To terminate a contest at any stage if one of the Boxers has received an injury on account of which the Referee decides the Boxer should not continue.
- 7.3.3. To terminate a contest at any stage if the Referee considers the Boxers are not in earnest. In such cases, the Referee may disqualify one or both Boxers.
- 7.3.4. To caution a Boxer or to stop the boxing during a contest and administer a warning to a Boxer against fouls or for any other reason in the interest of fair-play, or to ensure compliance with present Rules.
- 7.3.5. To disqualify a Boxer who fails to comply immediately with the Referee's orders, or behaves towards the Referee in an offensive or aggressive manner at any time.
- 7.3.6. With or without previous warning, to disqualify a contestant for committing a serious foul.
- 7.3.7. In the event of a Knock-Down, to suspend a count, if a Boxer deliberately fails to retire to a neutral corner or delays to do so.
- 7.3.8. To interpret present Rules insofar as they are applicable or relevant to the actual contest or to decide and take action on any circumstance of the contest which is not covered by a rule.
- 7.4. Right to check the Boxer
- 7.4.1. Equipment and Uniform - Once a Boxer enters the ring, a Referee shall disqualify any Boxer who refuse to wear a headguard, a cup protector (only men) and a gumshield; however this situation can be immediately rectified at Referee's discretion within one minute failing which the Boxer will be disqualified. No other objects may be worn during the competition. In the event of a Boxer's gloves, headguard or uniform becoming undone during boxing, the Referee shall stop the contest to have it attended to.
- 7.5. Right to check the Judges
- 7.5.1. The Referee must check the right positions of the Judges before the bout.

RULE 8. JUDGES

8.1. Designation and Participation

- 8.1.1. In the Olympic Games and all AIBA Approved Events, each contest shall be marked by five AIBA Judges who shall be seated separated from the public and immediately adjacent to the ring.
- 8.1.2. Two of the Judges shall be seated on the same side of the ring at a sufficient distance from one another, and each of the other three Judges shall be seated at the center of one of the other three sides of the ring.

When the number of Officials available is insufficient, 3 Judges instead of 5 may be used, but this shall not apply to the Olympic Games, World Championships or Continental Championships.

8.2. Duties

- 8.2.1. Each Judge shall independently judge the merits of the two Boxers and shall decide the winner according to the present Rules.
- 8.2.2. Each Judge shall use the AIBA Scoring System for judging the merits of the Boxers.
- 8.2.3. Each Judge shall not speak or give any sign to a Boxer or to another Judge or to anyone else during the contest.
- 8.2.4. Each Judge can, should it be necessary and at the end of a round, bring to the attention of the Referee any incident which the Referee may appear not to have noticed such as the misconduct of a Second, loose ropes, etc.
- 8.2.5. Judges shall remain in their seated positions until after the verdict has been announced to the public.

RULE 9. AIBA REFEREES & JUDGES MANAGEMENT

- 9.1. The entire management system for AIBA Referees & Judges is described in Appendix G.

RULE 10. COACHES

10.1. Certification

- 10.1.1. All current coaches in National Federations must obtain an AIBA official certification to be allowed to second Boxers in the different AIBA Approved Events.
- 10.1.2. The coach classification shall be divided into three (3) levels and respect the following principles:
 - 10.1.2.1. 1-Star level Coaches and above are allowed to be Second at 1-Star level events
 - 10.1.2.2. 2-Star level Coaches and above are allowed to be Second at 2-Star level events
 - 10.1.2.3. Only 3-Star level Coaches are allowed to be Second at 3-Star level events.
- 10.2. Before the new Coaches Management System is in place, a grace period shall be opened until the end of December 2012 to allow a lower Star level Coach to perform as Second in any higher level event in case a National Federation does not have any sufficient level certified Coaches.

RULE 11. AIBA COACHES MANAGEMENT

- 11.1. The entire management system for AIBA Coaches is described in Appendix M.

RULE 12. SECONDS

12.1. Number of Seconds

- 12.1.1. Each Boxer is entitled to two (2) Seconds who shall be governed by the following rule: Only the two (2) Seconds shall mount the apron of the ring and only one may enter the ring.

12.2. Duties

- 12.2.1. During the boxing, none of the Seconds shall remain on the platform of the ring. Before a round begins, they shall remove seats, towels, buckets, etc., from the platform of the ring.
- 12.2.2. The Seconds, while officiating in the corner, shall be in possession of a towel for the Boxer. A Second may indicate retirement for the Boxer by throwing the towel into the ring, when the Second considers the Boxer to be unfit / unable to continue boxing, except when the Referee is in the course of counting.
- 12.2.3. The Seconds are the Coaches and Trainers who are qualified in their National Federation and must respect and follow the present Rules and each Boxer is also responsible in a same way for Seconds.

12.3. Coaches/Seconds in AIBA and WSB Matches

- 12.3.1. Any Coach active in professional boxing shall not be allowed to be a Coach and/or Second in both AIBA and/or WSB competitions at any level unless the Coach resigns from any involvement in professional boxing for a period of at least six (6) months and is certified by AIBA as a registered Coach.

12.4. Prohibited Activities

- 12.4.1. A Second should not be permitted to shout loud, to clap to the Boxer and/or the Referee, to encourage or incite spectators by words or signs during the progress of a round.
- 12.4.2. The Second's seating are should be 50cm to 1 meter away from the ring corner within 1.5-2m2 (see Appendix I – Field of Play). A Second should not be permitted to walk off the Second's designated area with disagreed actions against the Referee.
- 12.4.3. A Second should not be permitted to throw any item into the ring to demonstrate a disagreement or to kick any chair or water bottle or to take any other action that may be deemed as unsportsmanlike behavior.
- 12.4.5. The use of any communication device shall not be permitted onto the Field of Play such as but not limited to mobile telephones, walkie-talkies, smart phones, headsets, shortwave radios, etc.
- 12.4.6. Under no circumstance should the Second administrate supplemental oxygen to a Boxer during a bout.

12.5. Sanctions

- 12.5.1. For a 1st violation on any of above prohibited activities, the Second shall receive a caution.
- 12.5.2. For a 2nd violation on any of above prohibited activities, the Second shall receive a warning and be place just outside of the FOP area and be allowed to remain the Competition Venue.
- 12.5.3. For a 3rd violation on any of the above prohibited activities, the Second shall be removed by the Chairman of the Competition Jury for the rest of the day.
- 12.5.4. If this Second is removed for a second time, this Second shall be completely suspended from the competition.

RULE 13. MEDICAL JURY

13.1. Qualification

- 13.1.1. For all AIBA Approved Events, Olympic Games and Olympic Qualifying Events, only AIBA Medical Commission members are permitted to serve as Medical Jury members. For all Confederation Approved Events, only Confederation Medical Commission members are permitted to serve as Medical Jury members.
- 13.1.2. In emergency conditions, the Technical Delegate may appoint local or Team Doctors in case other Medical Jury members are not available.

13.2. Attendance in Competition

- 13.2.1. Medical Jury members should be in attendance throughout the competition and should not leave the place where it is held before the end of the last bout and until Medical Jury members has seen the two Boxers who participated in such bout. Medical Jury members may wear surgical gloves during the bout.

13.3. Number of Medical Jury Members

- 13.3.1. In the case of one ring, in all AIBA Approved Events including the Olympic Games and World Championships, a minimum of two (2) and maximum of three (3) AIBA Medical Jury members are appointed. However, in any case, there shall not be more than two (2) Medical Jury members at one ringside.
- 13.3.2. In the case of two rings, in all AIBA Approved Events including the Olympic Games and World Championships, a maximum of two (2) AIBA Medical Jury members for each ring is required.

13.4. Requirement for Anti-Doping

- 13.4.1. For any AIBA Approved Event, one (1) anti-doping specialist should be present to control the anti-doping process under the supervision of the Medical Jury members.

13.5. Main Duties

13.5.1. General Duties

- 13.5.1.1. The Medical Jury members are designated for Medical Examinations to ensure that:
 - The Boxers have enough space
 - There is a direct access to the Weigh-In room
 - There exists some heating (if necessary), sufficient light and adequate ventilation
 - There is a sufficient number of chairs and desks.
- 13.5.1.2. At all international competitions, an AIBA Medical Commission member shall be present at the initial Medical Examination and all subsequent pre-bout examinations of Boxers.
- 13.5.1.3. Medical Jury members shall assist medical officers from individual countries.
- 13.5.1.4. Medical Jury members may express their opinion on injuries that Boxers have sustained and this opinion must be given when invited to do so by the Referee. This opinion will be considered as final.
- 13.5.1.5. Medical Jury members shall provide a Medical Doctor to oversee doping procedures and inspect the designated doping areas to determine adequacy in location, equipment, provisions and forms.

13.5.1.6. Medical Jury members shall provide Medical Examination for Referees & Judges.

13.5.1.7. Medical Jury members shall review the emergency plans of the Organizing Committee:

- Check for the presence of oxygen and stretcher, other resuscitation equipment, evacuation equipment, route of evacuation
- Check that an ambulance is present for competition and hospital designated to care for stricken Boxers.

13.5.1.8. Medical Jury members shall check for adequate food and hydration provisions to be provided for the Boxers and recommended to the Technical Delegate for approval.

13.5.2. Competition Duties

13.5.2.1. At least one member of the Medical Jury must be at ringside for the entire duration of a bout.

13.5.2.2. Medical Jury members shall direct the Referee in evaluating injuries.

13.5.2.3. Medical Jury members shall inform the Chairperson of the Competition Jury to stop the bout in the case any Boxer appears unable to continue.

13.5.3. Procedure after Knock-Out and RSCH

13.5.3.1. Unconscious Boxer - If a Boxer is rendered unconscious, then only the Referee and the Doctor summoned should remain in the ring, unless the Doctor needs additional help. In case a Boxer is unconscious for more than one (1) minute, this Boxer should be transported to the nearest hospital (if possible to the neurosurgery department) for further evaluation. Any Boxer with a concussion may be referred to the hospital by the Doctor.

13.5.3.2. Medical Attention - In the case of a Knock-Out without unconsciousness or in the case of RSCH, the Boxer shall be examined by a Doctor immediately afterwards in the locker room to determine the need and nature of further medical observation and/or hospitalization.

13.5.3.3. Medical Jury members may recommend treatment for injured Boxers.

13.5.3.4. Medical Jury members will suspend and restrict injured Boxers as they feel appropriate.

RULE 14. TIMEKEEPER

14.1. Duties

13.1.1. The main duty of the Timekeeper is to regulate the number and duration of the rounds and the intervals between rounds. The intervals between rounds shall be of a full minute duration.

14.1.2. Five seconds before the start of each round, the Timekeeper shall clear the ring by ordering "clear the ring" or "Seconds out".

14.1.3. The Timekeeper shall start and end each round by striking the gong or bell.

14.1.4. The Timekeeper shall announce the number of each round immediately prior to starting it.

14.1.5. The Timekeeper shall stop/resume the clock as instructed by the Referee.

14.1.6. The Timekeeper shall regulate all periods of time and counts by a watch or clock.

14.1.7. At a Knock-Down, the Timekeeper shall give the sound signal to the Referee indicating the elapsing seconds while the latter is counting.

14.1.8. If, at the end of a round, a Boxer is “down” and the Referee is in the course of counting, the gong indicating the end of the round will not be sounded. The gong will be sounded only when the Referee gives the command “box” indicating the continuation of the bout. When the Referee is in the course of counting, the time of the round cannot finish, because of the command “stop” given by the Referee.

14.2. Position

14.2.1. The Timekeeper shall be seated directly at the side of the ring.

RULE 15. OFFICIAL ANNOUNCER

15.1. Qualification

15.1.1. For all AIBA Approved Events, the Official Announcer should have the following qualifications:

15.1.1.1. Fluent in multi-languages (English is mandatory)

15.1.1.2. An excellent understanding of the AIBA Technical & Competition Rules

15.1.1.3. Possess a minimum of three (3) year experience in the field of competition announcement in sports events.

15.2. Appointment

15.2.1. The Organizing Committee is responsible to hire a professional announcer for the entire competition.

RULES FOR COMPETITION EQUIPMENT

RULE 1. USE OF AIBA LICENSEE EQUIPMENT

- 1.1. From January 2012, for all AIBA Approved Events, Confederation Approved Events and all National Events, only AIBA Official Licensed Gloves and Headguards manufactured by AIBA Official Licensees must be used.

RULE 2. RING AND ACCESSORIES

- 2.1. All specifications and guidelines on ring and accessories are described in Appendix H.
- 2.2. Approved Label
 - 2.2.1. For all AIBA Approved Events, the Organizing Committee should use the rings manufactured by one of the AIBA Official Licensees.

RULE 3. GLOVES

- 3.1. At all AIBA Approved Events, Boxers must use gloves manufactured by one of the AIBA Official Boxing Equipment Licensees.
- 3.2. Boxers shall wear red or blue gloves, as per the respective Boxer's corner.
- 3.3. At all AIBA Approved Events, the gloves have to be provided by the Organizing Committee and have to be approved by the Technical Delegate. Boxers are not allowed to wear their own gloves.
- 3.4. Boxers shall put on their boxing gloves before entering the ring.
- 3.5. The gloves shall be taken off immediately after the bout is over and before the decision is announced.
- 3.6. The padding of the gloves shall not be displaced or broken.
- 3.7. Only clean and serviceable gloves shall be used.
- 3.8. Specifications
 - 3.8.1. Detailed specifications on boxing gloves can be found in the Glove and Headguards Specifications and Guidelines in Appendix J.

RULE 4. HEADGUARDS

- 4.1. At all AIBA Approved Events, Boxers must use headguards manufactured by one of the AIBA Official Boxing Equipment Licensees.
- 4.2. The use of a headguard is mandatory.
- 4.3. Boxers shall wear red or blue headguards, as per the respective Boxer's corner.

- 4.4. At all AIBA Approved Events, the headguards have to be provided by the Organizing Committee and have to be approved by the Technical Delegate. Boxers are not allowed to wear their own headguard.
- 4.5. Boxers shall put their headguard on only after entering the ring.
- 4.6. Headguards shall be taken off immediately after the bout is over and before the decision is announced.
- 4.7. Specifications
 - 4.7.1. Detailed specifications on headguards can be found in the Equipment Guidelines in Appendix J.

RULE 5. BANDAGES

- 5.1. Use of Bandages
 - 5.1.1. At all AIBA Approved Events, Boxers must use bandages from one of the AIBA Official Boxing Equipment Licensees.
 - 5.1.2. Bandages shall be applied in the dressing room in the presence of a Host National Federation Official. The bandages on each Boxer shall be checked and marked by the official Equipment Manager at the equipment check table.
- 5.2. Specifications
 - 5.2.1. A bandage must not be longer than 4.5m (14.76 feet), and not shorter than 2.5m (8.2 feet). The bandage should be 5.7cm (2 ¼ inches) wide.

RULE 6. GUMSHIELD

- 6.1. A gumshield must be worn. The gumshield should be form-fitted. The gumshield must be made available by the Organizing Committee for any participant who does not have one, and deducted against payment by the Boxer concerned or the Boxer's National Federation. No red or partially red colored gumshield may be worn.

RULE 7. PROTECTORS

- 7.1. For all Men competitions, a cup protector shall be worn by the Boxers during all bouts and a jock-strap may be worn additionally. The cup protector should not cover any part of the target area.
- 7.2. For all Women competitions, a breast protector and a pubic protector may be worn by the Boxers.
 - 7.2.1. Women's breast protectors shall be constructed to protect the soft tissue of the breast up to the point that the breast protrusion merges with the chest wall. Breast protectors may not shield any other target area of the body except the protrusion of the breast. Right and left breast protectors, if connected, must be connected by thin material that does not protect the breastbone. Normal «bra straps» are permitted to hold the protectors in place. Breast protectors must have no metal parts except at the fastening site at the back of the Boxer.

RULE 8. COMPETITION UNIFORM

8.1. Boxers' Uniform

- 8.1.1. Boxers shall box in light boots or shoes (without spikes or heels), socks, shorts (not to exceed knee length), and a vest covering the chest and back.
- 8.1.2. For all AIBA Approved Events, Men Boxers must wear a red or blue vest and shorts per the Boxers' respective corner allocation, which shall be their own responsibility.
- 8.1.3. For all AIBA Approved Events, Women Boxers must wear a red or blue form fitting vest and either shorts or the option of a skirt as per the Boxers' respective corner allocation, which shall be their own responsibility.
- 8.1.4. The belt line of any shorts or skirt must be clearly indicated by a contrasting color and by using a 6-10cm wide elastic waistband (the belt line is an imaginary line from the navel to the top of the hips).
- 8.1.5. Boxers shall not be allowed to have tape, in any form, on their uniform.

8.2. Specifications

- 8.2.1. Detailed Boxers' Uniform Guidelines can be found in Appendix F.

8.3. Attire of the Officials (Referees & Judges)

- 8.3.1. Referees & Judges shall be dressed in trousers and shirts following AIBA's instructions for each competition.
- 8.3.2. These officials may use surgical gloves when officiating.

RULE 9. AIBA SCORING SYSTEM EQUIPMENT

- 9.1. For all AIBA Approved Events, a complete set of AIBA Scoring System and an AIBA Scoring System Operator are mandatory.
- 9.2. Handheld Scoring Clickers
 - 9.2.1. The Judges will also require five (5) handheld scoring clickers in the event of a breakdown of the AIBA Scoring System.

APPENDIX A

DUTIES OF AND GUIDELINES FOR COMPETITION OFFICIALS

1. DUTIES OF AND GUIDELINES FOR THE TECHNICAL DELEGATE (TD)

1.1. The TD shall arrive at the Championships' location at least forty-eight (48) hours before the Technical Meeting.

1.2. Before the Technical Meeting:

1.2.1. Together with the Competition Manager, the TD shall review:

- a. Structure and transport planning
- b. Accommodation
- c. Food - dining times available
- d. Accreditation
- e. Competition material
- f. Location of training facilities
- g. Location of competition
- h. FOP layout
- i. Security
- j. Scoring system and displays for the public
- k. Lounge for R&Js with the necessary comfort
- l. Lounge for International Technical Officials
- m. Meeting room
- n. TD Office with computer, printer and Internet
- o. Entry for R&Js and all Officials
- p. Entry for public
- q. Locker rooms
- r. Location of warm-up area
- s. Location of equipment room
- t. Location of room for doping tests
- u. Medical department facilities
- w. Location and layout for the Weigh-in and Medical Examination

1.3. Technical Meeting:

1.3.1. The TD shall ensure that the Technical Meeting is done one (1) day before the Medical Examination and General Weigh-in and preferably at night, to ensure the presence of all countries, except if the Weigh-In happens a day before the competition.

1.3.2. It should be handled together with the Competition Manager, with translation into the main languages spoken at the Championships.

1.3.3. The TD shall ensure that participating delegates and coaches receive all necessary technical and administrative information for the Championships as well as:

- a. Confirm the entries of Boxers
- b. Location and time of Weigh-In and Medical Examination
- c. List of documents to be submitted at Weigh-in and Medical Examination
- d. Location and time of the Official Draw

- e. Explanation of the seeding system
- f. Location and competition schedule
- g. Reminder of important rules such as:
 - g1. Red mouthpiece
 - g2. Belt line different color for the vest and trunk
 - g3. Boxers to be clean shaven without mustaches at Weigh-In (men)
 - g4. Declaration of non-pregnancy at the Weigh-In (women)
 - g5. Number of rounds
 - g6. Maximum KD
 - g7. Headguard to be put on after entering the ring
 - g8. All competition material to be provided by the Organizing Committee
 - g9. No other competition material to be used
- h. Introduce the Officials who shall work at the Championships and their functions

1.4. Meeting with ITOs:

1.4.1. After the Technical Meeting, the TD shall meet with ITOs and:

- a. Explain roles
- b. Give information about transportation schedules, meetings, competition
- c. Provide general details.

1.4.2. The TD shall provide FOP stickers for credentials if necessary.

1.4.3. The TD shall confirm the arrival of the R&Js and inform them on their Medical Check to be held the next day after the Medical Examination.

1.4.4. The TD shall sign the Code of Conduct.

1.4.5. The TD shall divide the R&Js in five (5) groups according to get the best neutrality, informing the Chairman of the Draw Commission.

1.4.6. The TD shall assign:

- a. Competition Jury – three (3) persons and one (1) more in stand-by in case of a bout involving a Boxer from the same country as one of the members, this for each ring
- b. Draw Commission (min. two (2) persons)
- c. R&Js Coordinator
- d. Equipment Manager

1.4.7. The TD shall inform the ITOs of the schedule for Daily Weigh-In.

1.4.8. The TD shall inform the Chairman of the Medical Jury about the Medical Examination.

1.5. Weigh-In and Medical Examination (General and Daily)

1.5.1. The TD shall arrive at least thirty (30) minutes before the scheduled start time.

1.5.2. The TD shall check if testing scales are calculating the same weight as the official scales.

1.5.3. Together with the Competition Manager, the TD shall organize the line of the Boxers.

1.5.4. The TD shall distribute the lists of the Boxers divided into Weight Categories to Medical Doctors and Officials, in order to check the documents, and control the Weigh-In.

- 1.5.5. The TD shall authorize the start of Weigh-in and Medical Examination.
 - 1.5.6. The TD shall potentially authorize the start of the Weigh-In and Medical Examination before the scheduled start time, but to always respect the scheduled time to complete them.
 - 1.5.7. The TD shall ensure that the Weigh-In of Women Boxers is done by Officials of the same gender and in a private place.
 - 1.5.8. The TD shall be on the premises of the Weigh-in and at all times available to supervise the work and solve potential issues.
 - 1.5.9. At the end of the Weigh-In, the TD shall collect the sheets signed by the Officials responsible for each Weight Category, with the occurred alterations.
 - 1.5.10. The TD shall deliver the International Competition Record Books to the Competition Manager or Official responsible for them.
 - 1.5.11. After the Medical Check of R&Js, the TD shall collect their Record Books with the Medical Doctors.
- 1.6. Official Draw:
- 1.6.1. With the sheets from the General Weigh-In, together with the Competition Manager, the TD shall do the daily schedules, thinking about Boxers' rest after competition, and of the potential of Championships to be seen by more people in the Competition Venue and on television.
 - 1.6.2. If possible, the TD shall schedule sessions with a maximum of three hours each.
 - 1.6.3. When schedules are ready, the TD shall conduct the Official Draw for all Weight Categories, and inform on the program of the first day.
 - 1.6.4. The TD shall ensure that after the Official Draw, each Team Delegation receives a copy of the results with the daily schedule.
- 1.7. Before the Competition:
- 1.7.1. The TD shall arrive at the Competition Venue at least two (2) hours before the start of the 1st bout.
 - 1.7.2. The TD shall confirm if the below is immediately available:
 - a. Gloves
 - b. Headguards
 - c. Bandages
 - d. Results sheets
 - e. Sheets for the Draw Commission
 - f. Clickers
 - g. R&Js evaluation sheets
 - h. Pads or flags for results in 3 different colors (red, white and blue)
 - i. Gloves and headguards on stand-by at the Competition Jury table.
 - 1.7.3. The TD shall check the FOP and to ensure the location of each ITO.
 - 1.7.4. The TD shall check the sound, scoring system, chronometer, computers, printers, etc.
 - 1.7.5. The TD shall meet with the Chairman of the Draw Commission, Chairman of the Competition Jury and Judges' Evaluator for analysis, evaluation and instructions.

- 1.7.6. The TD shall temporarily or permanently suspend an R&J if it is obvious that person has done an insufficient job.
 - 1.7.7. If necessary, the TD shall meet with the R&Js to review the Rules, comment on the work of the R&Js always with the intention of improving performance.
 - 1.7.8. The TD shall ensure that all officials are in place fifteen (15) minutes before the 1st bout.
 - 1.7.9. The TD shall approve the R&Js of the 1st bout.
 - 1.7.10. The TD shall confirm the R&Js, Competition Jury and Medical Jury members, five (5) minutes before the 1st bout.
 - 1.7.11. The TD shall arrange the rotation of the Competition Jury members.
- 1.8. During the Session:
- 1.8.1. The TD shall check and sign the R&Js Draw sheets of each bout.
 - 1.8.2. The TD shall receive the results of each bout.
 - 1.8.3. The TD shall pay attention to the FOP to maintain discipline and order.
 - 1.8.4. The TD shall not allow photographers or cameramen to disturb the work of Judges.
 - 1.8.5. The TD shall ensure that the Competition Manager is in direct contact for necessary action.
- 1.9. After the Session:
- 1.9.1. The TD shall receive the schedule for the following day.
 - 1.9.2. The TD shall receive International Competition Record Books of the Boxers who shall compete on the next day.
 - 1.9.3. The TD shall ensure there is transportation for the Medical Doctor who is handling doping tests.
 - 1.9.4. The TD shall meet with the Competition Manager to evaluate the day and possible changes for the next day.
 - 1.9.5. The TD shall send to AIBA or Continental Confederation all results and photos.
 - 1.9.6. At the end of the competition, the TD shall sign and deliver to the R&Js their Record Books with the total of the bouts worked.
- 1.10. Eligibility:
- 1.10.1. If a complaint on the eligibility of a Boxer is received, the TD shall report this immediately to the AIBA HQs Office and if an illegibility case is confirmed, the TD shall disqualify the Boxer immediately and inform all parties.
- 1.11. Report:
- 1.11.1. The TD shall send to AIBA or Continental Confederation in a maximum of forty-eight (48) hours after the Finals:
 - a. General report
 - b. Evaluations by Judges' Evaluator
 - c. Assessments of the Referees by the Competition Jury with average of the grades received
 - d. Recommendations to change the status of R&Js into 1-, 2- or 3-Star, upgrade or downgrade.

2. DUTIES OF AND GUIDELINES FOR THE DEPUTY TECHNICAL DELEGATE (DTD)

- 2.1. If a DTD is appointed, he/she shall assist and implement any and all instructions from the Technical Delegate.

3. DUTIES OF AND GUIDELINES FOR THE COMPETITION JURY (CJ)

- 3.1. The CJ shall be formed by three (3) persons from different countries. One (1) of these persons shall be appointed as the Chairman by the Technical Delegate. One (1) additional person shall be on stand-by.
- 3.2. The Chairman of the CJ and at least one (1) other member should have an R&J background and be either AIBA and/or Confederation R&J Commission Members or Executive Committee Members with an R&J background. The third member may either have an R&J background similar to that of the other two members, or be a member of the AIBA Technical & Rules Commission.
- 3.3. The CJ shall be in the FOP at least thirty (30) minutes before the start of the 1st bout in every session.
- 3.4. The CJ shall ensure that everything in its area of responsibility is available and ready such as: Timekeeper, Medical Jury, Scoring System, Scoring System Operator, Gloves and headguards on reserve, Pads or flags for results in 3 different colors (red, blue and white), Clickers, Results sheets, Manual scoring sheets, Referee evaluation forms, Whistle, Pens, Volunteers for ring, Water, Ring dryer, Condition of the ring, Sound system, Clock, Bell, Announcer, Judges' Evaluator, R&Js for the 1st bout, Boxers for the 1st bout.
- 3.5. The CJ shall ensure that the R&Js are in the correct positions before the Boxers come to the ring.
- 3.6. The CJ shall ensure that the Judges are in the right position according to the R&J draw sheet and that right NOC codes of the Boxers and R&Js appear on the Computer
- 3.7. The Chairman of the CJ shall allow the start of the bout only once all checks are completed.
- 3.8. One (1) member of the CJ shall carry out the Referees' evaluation.
- 3.9. The Chairman of the CJ shall be responsible for checking the behavior of the Seconds, assisted by the two (2) other members of the CJ.
- 3.10. The CJ shall note the results after each round for reference.
- 3.11. At the end of the bout, the CJ shall complete the decision sheet and hand it over to the Announcer.
- 3.12. When there is a draw, the CJ shall raise the white pad and wait for the final judgment, then complete the decision sheet for the Announcer.
- 3.13. During the announcement of the winner, the CJ shall raise the proper color pad or flag.
- 3.14. If the Chairman of the CJ receives a protest, he/she has the right to accept or reject.
- 3.15. If the protest is accepted by the Chairman of the CJ, it should immediately be reported to the TD.
- 3.16. After the session, the CJ shall start the protest procedure.

4. DUTIES OF AND GUIDELINES FOR THE DRAW COMMISSION (DC)

- 4.1. The DC shall be formed by three (3) persons from different countries which must also be different from the Technical Delegate's country. One (1) of these persons shall be appointed as the Chairman by the Technical Delegate.
- 4.2. At 3-Star Events, such as World Championships and Olympic Games, the DC members shall be from a different continent.
- 4.3. The DC members shall speak a common language.
- 4.4. The DC shall have the following knowledge:
 - a. To which continent each country participating belongs
 - b. To which continent and country each R&J participating belongs
 - c. Which countries are colonies of another
 - d. Which countries do speak the same language
 - e. Which countries are sharing geographical borders
 - f. Official NOC abbreviation of each country participating
 - g. Information pertaining to wars, political conflicts, religious conflicts, rivalries, and so on.
- 4.6. The Chairman of the DC shall meet with the TD to confirm the five (5) groups of R&Js to be divided and receive instructions for the appointment of R&Js.
- 4.7. Every day, the Chairman of the DC shall attend the meeting with the TD to receive instructions in case any R&J is suspended, excluded or a suspension lifted.
- 4.8. Twenty (20) minutes before the start of the session, the DC shall prepare the first two (2) bouts.
- 4.9. When the 1st bout begins, the DC shall prepare the next two (2) bouts.
- 4.10. After the 2nd bout, the DC shall prepare one (1) bout each time until the end of the session.
- 4.11. The DC shall ensure that in competitions that use two (2) rings R&Js are working in both rings; a group of R&J shall never be split for each ring.
- 4.12. The DC shall ensure that an R&J is not named for the second ring at the same time as the first.
- 4.13. The DC shall always think of neutrality for nominations, consider country, region and continent.
- 4.14. The DC shall never appoint an R&J for a bout when a Boxer is of the same country as the R&J.
- 4.15. The DC shall not allow others to be or congregate around the DC table, with the exception of the TD when he needs to discuss any appointment.
- 4.16. The DC shall remain at the DC table until the last bout of the session.
- 4.17. When an R&J designated for a bout is of the same country as one of the DC members, the DC shall ensure that this member leaves the table and waits in a place indicated by the TD until the other members prepare the next nominations.
- 4.18. During a bout in which one (1) of the Boxers is of the same country as one of the DC members, the DC shall ensure that this member leaves the table and waits in a place indicated by the TD until the end of the bout.

- 4.19. The Chairman of the DC shall appoint a member to make control and statistics on the number of performances of each R&J and if an R&J works multiple times in a bout involving the same country.
- 4.20. The appointment of R&Js should be given to the TD for approval on a form signed by the Chairman of the DC together with five (5) copies.
- 4.21. In a bout involving Boxers from the same country as the Chairman of the DC, the form must be signed by a member of the DC who participated in the nominations.
- 4.22. If a member of the DC needs be absent from the table, this member must inform the TD.
- 4.23. The DC shall appoint a Judge from each of the five (5) groups. In exceptional cases or for better neutrality, two (2) Judges of the same group can be used.
- 4.24. The DC shall accept the changes proposed by the TD, unanswered.

5. DUTIES OF AND GUIDELINES FOR THE REFEREES AND JUDGES' COORDINATOR (RJC)

5.1. Before the Competition

5.1.1. The RJC shall study the codes of the country of each R&J; all codes must be known during the competition.

5.1.2. The RJC shall know the respective number of each R&J according to the Scoring System.

5.2. Before each Session

5.2.1. The RJC shall arrive in the FOP twenty (20) minutes before the start of the session.

5.2.2. Fifteen (15) minutes before starting the session, the RJC shall collect the R&J assignment sheets for the 1st bout with the Chairman of the Draw Commission.

5.2.3. The RJC shall check if the Chairman of the Draw Commission signed the sheets.

5.2.4. The RJC shall check if the R&Js are in alignment with the R&J Codes.

5.2.5. The RJC shall ask the Technical Delegate to sign the sheets.

5.2.6. The RJC shall deliver the assignment sheets to:

- a. The Technical Delegate
- b. The Scoring System Operator
- c. The Chairman of the Competition Jury
- d. The Announcer
- e. The Host Broadcaster

5.2.7. Ten (10) minutes before the start of the 1st bout, the RJC shall call the R&Js for the 1st bout.

5.2.8. The RJC shall inform and show the R&Js where they need to wait prior to their schedule bout.

5.2.9. The RJC shall collect the R&J assignment sheets for the 2nd bout.

5.2.10. The RJC shall repeat 3.2.3 to 3.2.6. for the 2nd bout.

5.3. After the start of the Second Round - 1st bout

5.3.1. The RJC shall call the R&Js for the 2nd bout.

- 5.3.2. The RJC shall inform and show the R&Js where they need to wait prior to their scheduled bout.
 - 5.3.3. The RJC shall collect the R&Js assignment sheets for the 3rd bout.
 - 5.3.4. The RJC shall check if the Chairman of the Draw Commission signed the sheets.
 - 5.3.5. The RJC shall check if the R&Js are in alignment with the R&J Codes.
 - 5.3.6. The RJC shall ask the Technical Delegate to sign the sheets.
- 5.4. After the announcement of the result of the 1st bout
- 5.4.1. The RJC shall deliver the assignment sheets of the 3rd bout to:
 - a. The Technical Delegate
 - b. The Scoring System Operator
 - c. The Chairman of the Competition Jury
 - d. The Announcer
 - e. The Host Broadcaster
 - 5.4.2. At the same time the R&J assignment sheets are delivered to the Scoring System Operator, the RJC shall collect three (3) copies of the result from the 1st bout.
 - 5.4.3. The RJC shall deliver the bout result to:
 - a. The Chairman of the Competition Jury
 - b. The Judges' Evaluator
 - c. The Technical Delegate
- 5.5. After the start the Second Round - 2nd bout
- 5.5.1. The RJC shall call the R&Js for the 3rd bout.
 - 5.5.2. The RJC shall inform and show the R&Js where they need to wait prior to their schedule bout.
 - 5.5.3. The RJC shall collect the R&Js assignment sheets for the 4th bout.
 - 5.5.4. The RJC shall check if the Chairman of the Draw Commission signed the sheets.
 - 5.5.5. The RJC shall check if the R&Js correspond with the R&J Codes.
 - 5.5.6. The RJC shall ask the Technical Delegate to sign the sheets.
- 5.6. After the announcement of the result of the 2nd bout
- 5.6.1. The RJC shall deliver the R&J assignment sheets of the 4th bout to:
 - a. The Technical Delegate
 - b. The Scoring System Operator
 - c. The Chairman of the Competition Jury
 - d. The Announcer
 - e. The Host Broadcaster
 - 5.6.2. At the same time the R&J assignment sheets are delivered to the Scoring System Operator, the RJC shall collect three (3) copies of the result from the 2nd bout.

5.6.3. The RJC shall deliver the bout result to:

- a. The Chairman of the Competition Jury
- b. The Judges Evaluator
- c. The Technical Delegate

5.7. Remainder of Bouts

5.7.1. The RJC shall complete above sequence for all remaining bouts.

6. DUTIES OF AND GUIDELINES FOR THE MEDICAL JURY (MJ)

6.1. The main duties of the Medical Jury are listed in Rule 13.5. of the Rules for Competition Officials. Please refer to the AIBA Medical Handbook for more details.

7. DUTIES OF AND GUIDELINES FOR THE EQUIPMENT MANAGER (EM)

7.1. Before the Competition:

- 7.1.1. The EM shall arrive at the Competition Venue one hour before the start of the competition.
- 7.1.2. The EM shall check the equipment room and all equipment quality and quantity.
- 7.1.3. The EM shall check the EM table location and all necessary supplies such as: Scissors, scotch tape, markers, pens and daily competition schedules.
- 7.1.4. The EM shall meet with the Volunteer Coordinator as well as with volunteers to verify how many are available in order to determine the ways of communication, to give all necessary directions and explain all unclear matters.
- 7.1.5. The EM shall check locker rooms, rings, availability of water bottles for Seconds, ice, availability of daily competition schedule (bout order), monitors for Seconds, testing scales, gloves and headguards at Competition Jury table, etc.

7.2. During the Competition:

- 7.2.1. Thirty (30) minutes before the 1st bout, the EM shall start to verify and check the bandages of the Boxers
- 7.2.2. The EM shall check each Boxer's identification card, gumshield, cup or breast protectors, vest, trunk and the colors of them (if they are adequate to ring's corners).
- 7.2.3. The EM shall check if Women Boxers' hair is not tied with metal hairpins
- 7.2.4. The EM shall verify if the logos on Boxers' uniforms are in accordance with AIBA Technical & Competition Rules, and have improper ones removed if necessary.
- 7.2.5. The EM shall control the first ten (10) Boxers who are going to fight in first five (5) bouts. After the end of the 1st bout, the EM shall control the next two (2) Boxers (sixth pair), etc. The results of this control should be registered.
- 7.2.6. Just before the bout (before the Boxers enter the FOP), the EM shall verify the correctness of the entire boxing equipment of the Boxers once more.

7.3. General Preparation:

- 7.3.1. The EM must be in permanent touch with the TD when officiating in competition. The EM shall also have official protest forms available.
- 7.3.2. The EM shall prepare the following items nearby the EM table:
 - a. 10 oz gloves with AIBA certification - red and blue, 4-6 pairs more than the total number of Boxers, in complete set
 - b. Headguards with AIBA certification - red and blue - different sizes (S,M,L, XL), 4-6 more than the total number of Boxers, in complete set
 - c. Same color bandages - same length and width
 - d. Gumshields
 - e. Extra red and blue uniforms
 - f. Extra cup and breast protectors
 - g. White color belt in different sizes for Boxers' waist band

8. TD/ITO CLASSIFICATION AND CERTIFICATION

- 8.1. AIBA has three levels of TD/TO classification; in ascending order of seniority: ITO, Confederation TD and AIBA TD. TD/ITO certification is proven by the issuing of an official AIBA certificate and inclusion in the AIBA TD/ITO Database.
- 8.2. Section 9 below sets out the procedures and processes by which someone becomes a National TD/ ITO and progresses to the three international levels. A TD/ITO cannot skip a level.
- 8.3. In order to become certified as a TD/ITO, applicants must pass a written test, as set out in section 3 below. In order to stay certified on that level, a TD may work as TD of an AIBA Controlled Event, TD of a Confederation Event or ITO of an AIBA Approved or Controlled Event.

9. ELIGIBILITY TO BECOME TD/ITO

- 9.1. Individuals are eligible to become a TD/ITO if they are:
 - a. AIBA and/or Confederation Executive Committee Members
 - b. AIBA and/or Confederation Commission Members
 - c. President, Secretary General or Elected Executive of a National Federation
 - d. Paid employees of a National Federation
- 9.2. A Confederation TD shall automatically be moved up to the AIBA TD level after serving in three continental events as Confederation TD and after having passed the AIBA TD Test.

10. TD/ITO TEST PROCEDURE

- 10.1. All TD/ITO examinations consist of a written test only. A TD/ITO Examination can be taken no more than two times per year and no more than three times per each four-year Olympic Cycle.
- 10.2. TD/ITO Examiners must have an AIBA Technical Delegate certification.

11. TD/ITO PERFORMANCE MANAGEMENT AND EVALUATION

- 11.1. At AIBA Approved and Controlled Events, the TD shall evaluate ITOs based on criteria developed by the AIBA Technical & Rules Commission and the AIBA HQs Office.
- 11.2. The TD shall submit the evaluation results to the AIBA HQs Office who shall communicate these results to the Chairman of the Technical & Rules Commission and discuss on a regular basis.
- 11.3. The AIBA Executive Director shall evaluate TDs based on the criteria developed by the AIBA Technical & Rules Commission and discuss these with the TDs and the Chairman of the AIBA Technical & Rules Commission on a regular basis.

12. TD/ITO Database

- 12.1. The AIBA HQs Office shall maintain all records of TD/ITOs on their participation, evaluation and personal information.
- 12.2. Except the performance evaluation, all information shall be available to the public.

13. WSB SUPERVISOR MANAGEMENT

- 13.1. There are no restrictions on AIBA Olympic-style boxing TDs/ITOs working as WSB Supervisors and vice versa.

APPENDIX B AIBA CODE OF CONDUCT

The International Boxing Association (AIBA) hereby requests for your agreement of the following “Code of Conduct”, which will apply during the entire period of the [Name Event, Date Event].

- Code 1: I shall not receive any cash and shall not accept any gift that could be considered as a bribe from anyone excluding those to be received from the AIBA HQs Office as official souvenirs.
- Code 2: I shall not be under the influence of alcohol during the entire period of the [Name Event].
- Code 3: I shall not violate any norm of social behavior in my relation with members of the local and visiting countries' citizens.
- Code 4: I shall not use or carry any electronic communication device, including but not limited to, a mobile phone, a laptop and a tablet computer inside the Competition Venue.
- Code 5: I shall be available to attend all daily arranged Referee & Judge meetings for the entire period of the [Name Event].
- Code 6: I shall be available for fulfilling my duties for the competition as requested by the AIBA Technical Delegate.
- Code 7: I shall not collude or collaborate with any party by violating the AIBA Technical & Competition Rules.
- Code 8: I shall not collude or collaborate with any party by violating my judgment and duties as an AIBA Referee & Judge.
- Code 9: When performing my duties as an AIBA Referee & Judge, I shall not communicate with anybody about any competition related issue within the Competition Venue and/or any other location for the entire period of the competition, especially to persons from my own country such as National Federation members, International Technical Officials, Executive Committee members, media and the public.
- Code 10: I shall not conduct myself in any manner that is derogatory to AIBA.
- Code 11: I shall not smoke inside of the Competition Venue.
- Code 12: I shall respect and not violate the AIBA Disciplinary Code in any manner.

I accept the fact that any infringement of the above codes will be referred to the AIBA Disciplinary Commission / Executive Committee and could lead to an immediate sanction against me. Therefore, I hereby agree to AIBA's request.

Date: / /

NAME

FUNCTION

SIGNATURE

APPENDIX C

AIBA APPROVED EVENT GUIDELINES

1. AIBA APPROVED EVENTS

- 1.1. AIBA Approved Events are supported by AIBA through TV rights, sponsorships, Technical Delegate(s), R&Js depending on the defined level of the event as listed in 1.10.
- 1.2. In each year, AIBA will set the maximum number of AIBA Approved Events to be held in any one calendar year at its Executive Committee meeting.
- 1.3. An AIBA Approved Event may not be staged on the same day as another one, unless the two events are in different countries and do not share a common border.
- 1.4. In principle, no more than one (1) AIBA Approved Event may be staged in the same city in any one year.
- 1.5. A maximum of three (3) AIBA Approved Events can be staged in the same country depending on their consistent excellence and their tradition.
- 1.6. AIBA will only consider applications for AIBA Status from those countries that have previously held an International Tournament on a regular basis and which are approved by the National Federation.
- 1.7. Applications for AIBA Status shall be submitted to the AIBA HQs Office by National Federations by September of the year preceding the event.
- 1.8. Any National Federation applying for upgrading an event shall submit the application along with the results of all previous tournaments and reasons for upgrade.
- 1.9. Any National Federation applying for any AIBA Approved Event will need to fulfil AIBA's requirements such as budget, hosting fee, compliance with AIBA Technical & Competition Rules, Anti-Doping Code, TV coverage. The level of requirements will depend on the status of the Approved Event.
- 1.10. AIBA Approved Events are divided into three (3) levels (1-Star, 2-Star and 3-Star Events) depending on the number of Boxers participating from different countries and the level of the Boxers (World Ranked Boxers):
 - 1.10.1. AIBA 3-Star Events – AIBA International Tournaments:
 - 1.10.1.1. All following AIBA Controlled Events are controlled and managed by AIBA, and the rights belong to AIBA:
 - World Boxing Championships (Men and Women)
 - Youth World Boxing Championships (Men and Women)
 - Junior World Boxing Championships (Boys and Girls)
 - World Cup
 - President's Cup
 - All Qualifying Events for the Olympic Games and Youth Olympic Games
 - World Series of Boxing
 - 1.10.1.2. International and Continental Events with a participation of more than 20 countries and over 150 Boxers

- 1.10.2. AIBA 2-Star Events – AIBA Continental Events:
 - 1.10.2.1. International and Continental Events with a participation of between 13 – 19 countries and over 100 Boxers
- 1.10.3. AIBA 1-Star Events – AIBA Regional Events:
 - 1.10.3.1. International and Continental Events with a participation of between 1 – 12 countries.
- 1.11. Rules shall apply as follows:
 - 1.11.1. The AIBA Technical & Competition Rules shall apply to all AIBA Approved Events.
 - 1.11.2. The Anti-Doping Rules shall apply to all AIBA Approved Events, except in circumstances where another international organization recognized by AIBA is obliged to implement its own anti-doping rules, in which case those rules will prevail.

2. EVENT PROCEDURE APPROVAL

- 2.1. National Level Events:
 - 2.1.1. For National Level Events, the following order procedure needs to be respected:
 - 2.1.1.1. National Federation's approval is mandatory
 - 2.1.1.2. Confederation's approval is mandatory
 - 2.1.1.3. AIBA's approval may be requested
 - 2.1.2. All other events may be AIBA Approved Events or not, which is something the Host National Federation has the liberty to choose. However, in the case of Non-Approved Events, the AIBA Technical & Competition Rules must apply.
 - 2.1.3. An approval should be obtained no later than three (3) months before the competition starts.
 - 2.1.4. This procedure may be implemented for any Championships, Dual Matches, Invitations (team or individual) or all other Regional Events.
- 2.2. Continental Events:
 - 2.2.1. For Continental Level Events, approval needs to be given by the Confederation and/or by AIBA.
 - 2.2.2. This can be done for Continental Championships, Continental Events and International Multi-Continental Events.

APPENDIX D WORLD RANKING GUIDELINES

1. WORLD RANKING POINTS ALLOCATION (Men and/or Women)

- 1.1. The World Ranking points for each Boxer are accumulated over a two (2) year “rolling” period.
- 1.2. The World Ranking points will be awarded for each event and maintained in full for four (4) events.
- 1.3. From the 5th event onwards (up to a maximum of 7 events), any World Ranking point awarded will be decreased by 25% per event.
- 1.4. The Official AIBA World Ranking is issued after each event counting into the ranking system.
- 1.5. Every Boxer participating in a 3-Star Event as listed in Appendix C, except in all Qualifying Events for the Olympic Games and the Youth Olympic Games, will be ranked within the competition and will gain points depending on final result and position.
- 1.6. World Ranking points will be allocated as follows:

Ranking Events	Ranking points to earn for reaching the following place									
	1st	2nd	3rd	4th	5th	6th	7th	8th	9th	10th
World Championships	1200	800	700	650	500	450	400	350	100	90
Olympic Games	1300	900	800	750	600	550	500	450	100	0
Confederation Championships	800	600	500	450	300	250	200	150	0	0
Youth World Championships	800	600	500	450	300	250	200	150	0	0

- 1.7. A disqualified Boxer on violation of the Disciplinary Code including for Anti-Doping issues shall not be awarded with any ranking point.

2. EXTRA CRITERIAS (Men and/or Women)

- 2.1. Any Boxer who changes Weight Category will be awarded 75% of all granted points in the previous Weight Category.
- 2.2. Two (2) Boxers with the same amount of points will be **FIRSTLY** ranked by the number of competitions in which they participated.
- 2.3. In case two (2) Boxers have the same number of points gained in the same number of competitions, they will be ranked through the best result in the highest ranked competition as follows:
 - 2.3.1. World Championships
 - 2.3.2. Olympic Games
 - 2.3.3. Confederation Championships
 - 2.3.4. Youth World Championships

3. RESULTS PROTOCOL

3.1. In order to determine each place in a 3-Star Event, the Boxers ranking shall be classify as follows:

Rank	Place	Result
1	1	Gold
2	2	Silver
3	3	Loser vs Gold in Semi-Final (SF)
3	4	Loser vs Silver in Semi-Final (SF)
5	5	Loser vs Gold in Quarter-Final (QF)
5	6	Loser vs Silver in Quarter-Final (QF)
5	7	Loser in QF vs Loser to Gold in SF
5	8	Loser in QF vs Loser to Silver in SF
9	9	Loser vs Gold in Round of 16
9	10	Loser vs Silver in Round of 16

APPENDIX E

SEEDING PROCEDURE FOR THE DRAW CEREMONY

1. THE SEEDING PROCEDURE OF THE DRAW CEREMONY

- 1.1. To ensure even strength throughout the Draw and to avoid best World Ranked Boxers meeting in the early rounds, the draw may be seeded or arranged subject to the restrictions for all AIBA Approved Events (World Championships, Continental Championships) and for the Olympic Games as follows:
 - 1.1.1. No seeds if there are less than 4 entries in the Weight Category (Men and/or Women)
 - 1.1.1.1. A maximum of two seeds if there are 4 to 15 entries in the Weight Category;
 - 1.1.1.2. A maximum of four seeds if there are more than 15 entries in the Weight Category;
 - 1.1.1.3. A maximum of eight seeds if there are more than 31 entries in the Weight Category;
 - 1.1.1.4. A maximum of sixteen seeds if there are more than 63 entries in the Weight Category;
 - 1.1.2. The AIBA Seeding Commission will review the performances of the WSB Boxers before each World Championships and Olympic Games
 - 1.1.2.1. At the AIBA World Championships, in each Weight Category except in Heavyweight and Super Heavyweight, 4 additional seeding places to the quota described in Rule 1.1.1 will be allocated to the highest ranked WSB Boxers of the previous WSB season.
 - 1.1.2.2. At the AIBA World Championships, in Heavyweight and Super Heavyweight categories, 2 additional seeding places to the quota described in Rule 1.1.1 will be allocated to the highest ranked WSB Boxers of the previous WSB season.
 - 1.1.2.3. At the Olympic Games, in each Weight Category, 2 additional seeding places to the quota described in Rule 1.1.1 will be allocated to the highest ranked WSB Boxers of the previous WSB season.
 - 1.1.3. Seeding Quota for Host Country:
 - 1.1.3.1. For only the case in the AIBA World Championships, the Host Country will receive the 8th ranking seed in each Weight Category if any Boxer from the Host Country is not qualified for any position among 8 allocated seeds by both AIBA and/or WSB World Rankings.
- 1.2. For the Approved Events listed in Rule 1.1., the seeding of the Draw shall be controlled by AIBA. To accomplish this, all entries shall be forwarded by the Organizing Committee to the AIBA HQs Office.
- 1.3. The Draw shall be conducted as follows:
 - 1.3.1. The number of byes should be defined and placed
 - 1.3.1.1. When the number of Boxers is 4, 8, 16, 32, 64, 128, or any higher power of 2, they shall meet in pairs in the order drawn, as in Diagram 1, for 8 Boxers.
 - 1.3.1.2. When the number of Boxers is not a power of 2, there shall be byes in the first round of bouts. The number of byes shall be equal to the difference between the next higher power of 2 and the number of Boxers (e.g. with 17 Boxers, there are $32 - 17 = 15$ byes).
 - 1.3.1.3. The byes shall be placed as in Diagram 2.

- 1.3.2. The seeded entries shall be selected from the highest AIBA World Ranked Boxers and highest WSB Ranked Boxers in the event.
- 1.3.3. Seeded entries shall be placed as detailed in the example Draw in Diagram 2. Seeded entries in the top half of the Draw are placed at the top and bottom of their sections (e.g. eights or sixteenths), and in the bottom half of the Draw at the bottom and top of their sections.
- 1.3.3.1. Depending on the number of seeds as listed in Rule 1.1., the top 2 and 4 seeded entries shall be dealt with as follows and shown in Diagram 2 and Diagram 3 (eg.1 seed, 2 seed, 3 seed, 4 seed):
- Number 1 placed at the top of the diagram
 - Number 2 placed at the bottom of the diagram
 - Number 3 placed at the top half of the bottom of the diagram
 - Number 4 placed at the bottom half of the top of the diagram
- 1.3.3.2. The other seeds shall be dealt with taking regard of the requirements of Rule 1.1.
- 1.3.3.3. Numbers 5 to 8 or 9 to 16 are placed as shown in Diagram 2 and Diagram 3 (eg. 5-8 seed or 9-16 seed) and are drawn by lot by an independent panel of observers.
- 1.3.3.4. The remaining places shall be filled with non-seeded Boxers randomly by the Computerized Draw System.

DIAGRAM 1

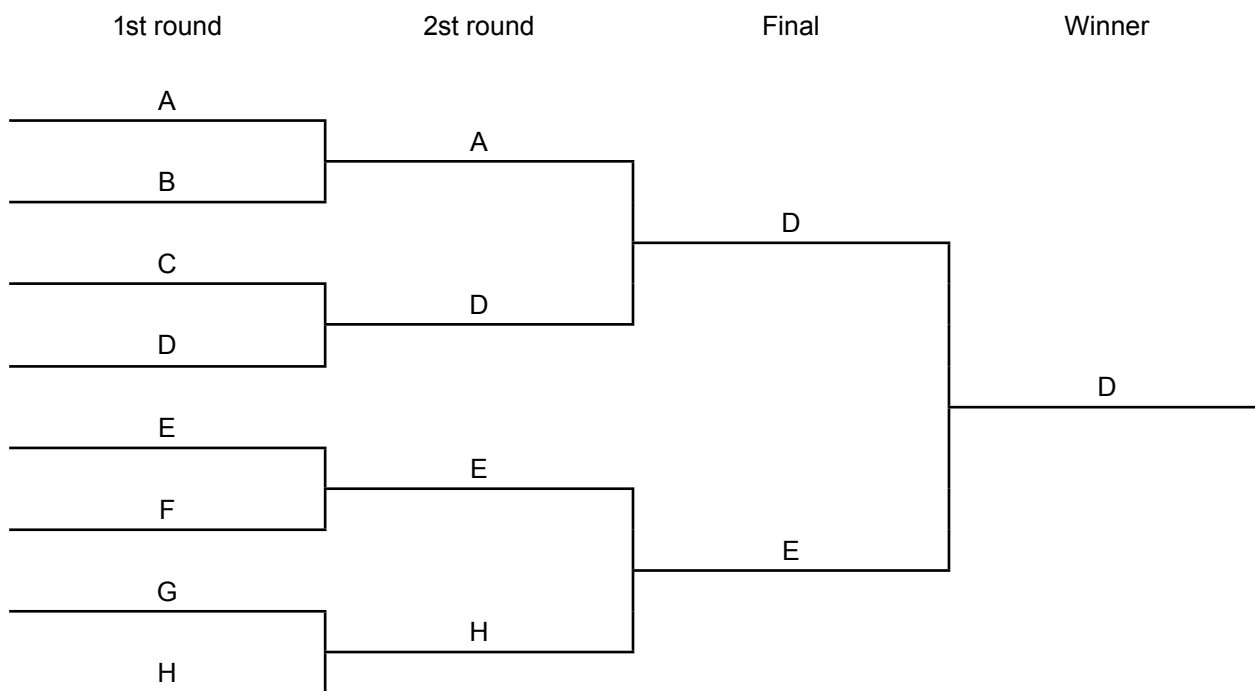

DIAGRAM 2

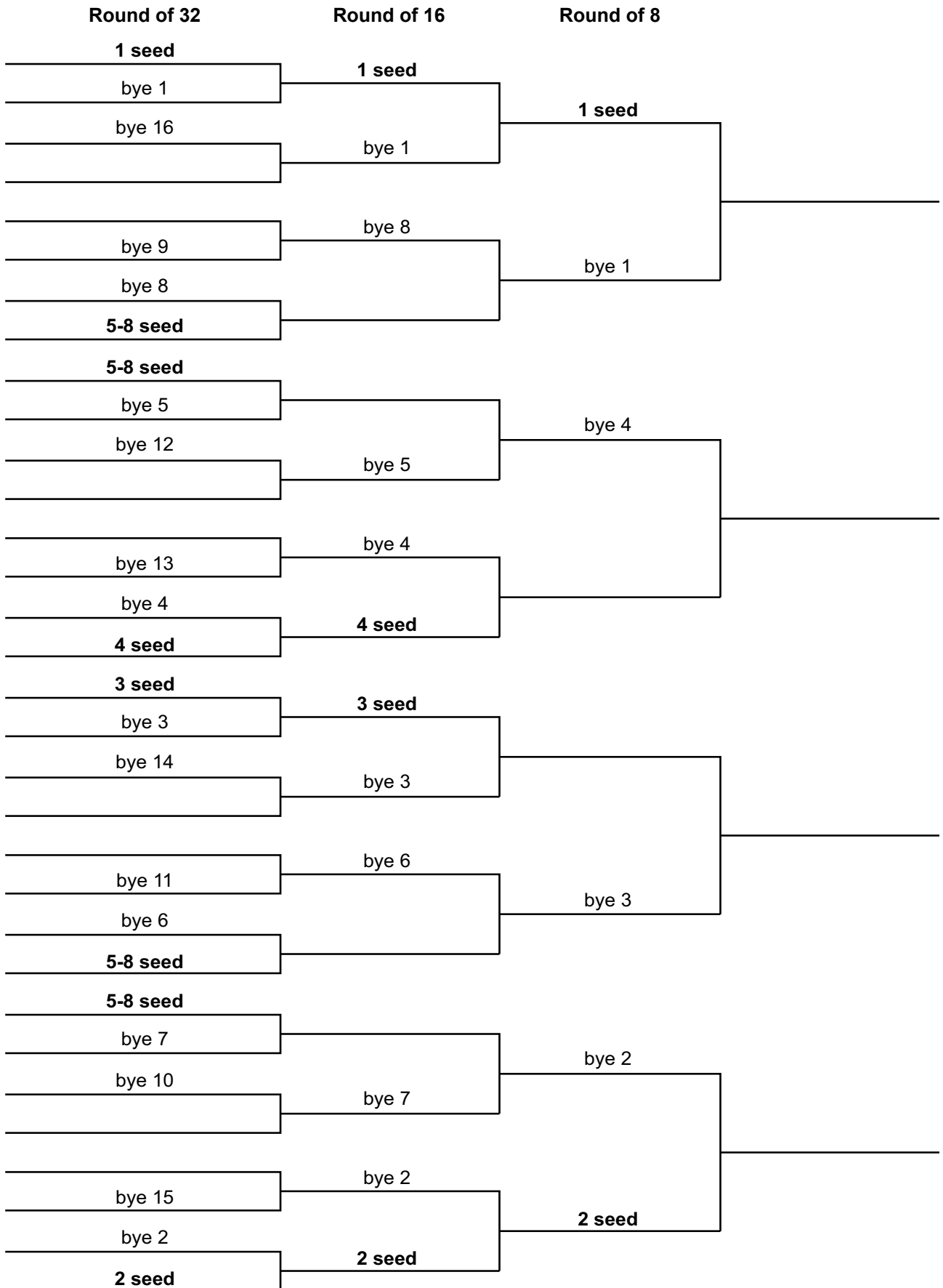

DIAGRAM 3

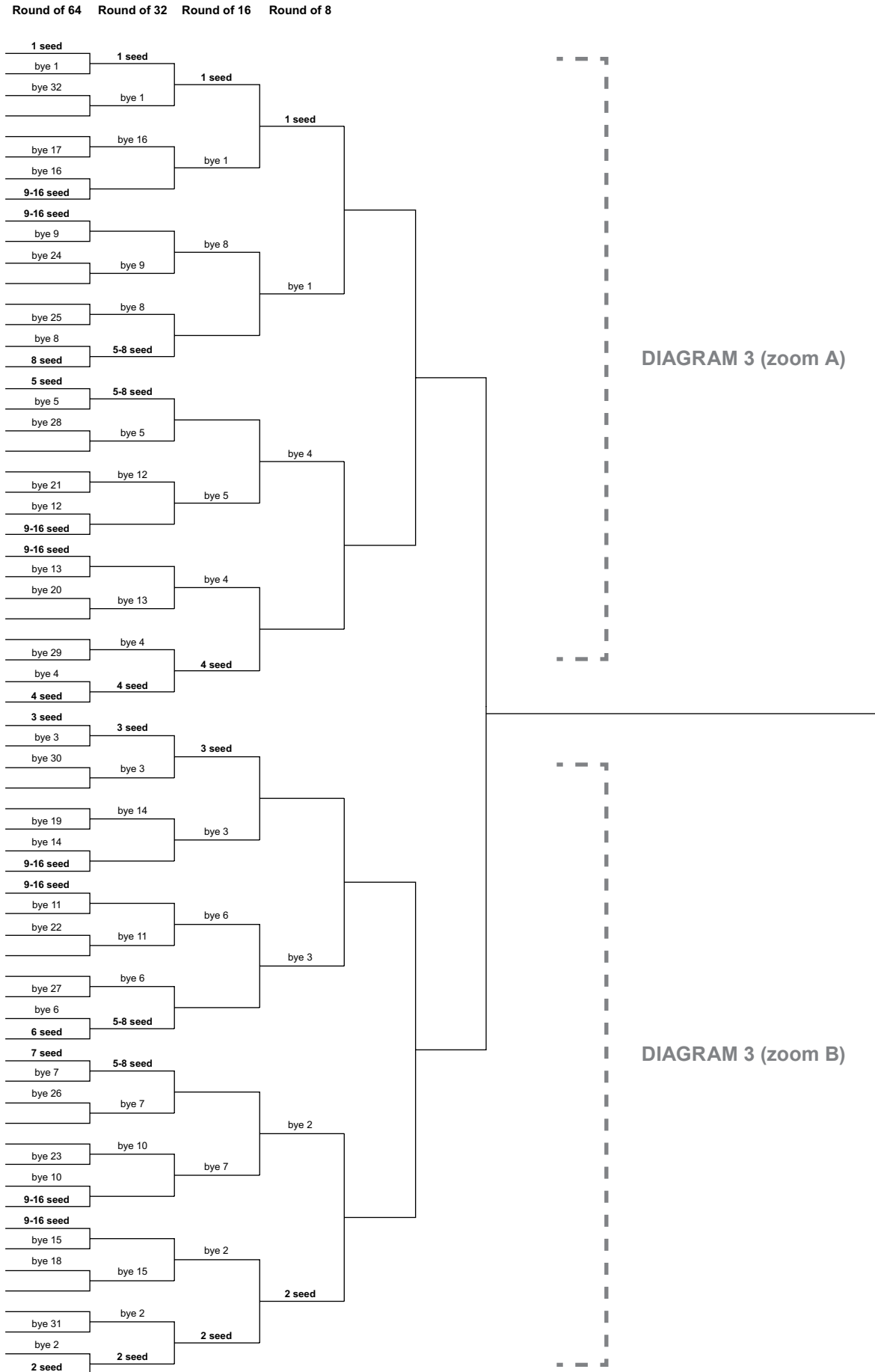

DIAGRAM 3 (zoom A)

DIAGRAM 3 (zoom B)

DIAGRAM 3 (zoom A)



DIAGRAM 3 (zoom B)



APPENDIX F

BOXERS' UNIFORM GUIDELINES

1. VEST AND SHORT/SKIRT SPECIFICATIONS

1.1. National Flag

- 1.1.1. The flag of the National Federation may be displayed only once on the vest and once on the shorts and/or skirt.
- 1.1.2. The flag must not contain any manufacturer identification, sponsor advertising, design features or other elements.
- 1.1.3. The flag may be printed, embroidered or sewn on as a badge.
- 1.1.4. There are no restrictions on the shape of the flag, but the following measurements and positioning on the kit item must be observed:
 - 1.1.4.1. Vest: Maximum 50cm² (fifty square centimeters) front of the vest, at heart level and side.
 - 1.1.4.2. Shorts and/or skirt: Maximum 50cm² (fifty square centimeters) front of left leg.

1.2. Manufacturers Logo

- 1.2.1. The manufacturer identification may be printed, embroidered or sewn on to the vest and shorts/skirt and must not interfere with the other elements identifying the National Federation (e.g. flag). The following quantities, positioning and measurements must be observed:
 - 1.2.1.1. Vest:
 - The logo identification is permitted to be positioned once on the front of the vest at chest level on the right area
 - Maximum 20cm² (twenty square centimeters).
 - 1.2.1.2. Shorts and/or skirt:
 - The logo identification is permitted to be positioned once at the front of right leg.
 - Maximum 20cm² (twenty square centimeters).

1.3. Olympic National Abbreviation of the National Federation

- 1.3.1. The Olympic National Abbreviation of the National Federation may be displayed only once on the back of the vest.
- 1.3.2. The letters used for the Olympic National Abbreviation of the National Federation must not exceed 10cm (ten centimeters) in height.
- 1.3.3. The letters used for the Olympic National Abbreviation of the National Federation must be in a contrasting color to the color(s) of the vest. For better legibility, they may be affixed to a neutral colored patch or surrounded by a border or shadow outline.
- 1.3.4. The Olympic National Abbreviation of the National Federation must not interfere with the other elements of the kit identifying the Boxer (e.g. Boxer's name).

1.4. Boxer's Name:

- 1.4.1. Each Boxer may be identified by means of the surname or popular name on the back of the vest. The name must be identical to that indicated in the passport.
- 1.4.2. The name must be positioned on the upper part of the back of the vest between the shoulder blades area. The letters used for the name must not exceed 5cm (five centimeters) in height and the name width should not exceed 20cm (twenty centimeters).
- 1.4.3. The letters used for the name must be in a contrasting color to the color(s) of the vest. For a better legibility, they may be affixed to a neutral colored patch or surrounded by a border or shadow outline.
- 1.4.4. They may not contain any manufacturer identification, sponsor advertising, design features or other elements.

1.5. National Federation Sponsors Advertising

- 1.5.1. All forms of advertising for sponsors or third parties, of political, religious or personal statements or other prohibited class such as alcohol (exception for beer and wine), tobacco, casino, gambling and betting are prohibited on all kit items inside the Competition Venue.
- 1.5.2. The National Federation sponsor advertising may be printed, embroidered or sewn on to the vest and must not interfere with the other elements identifying the National Federation (e.g. the flag). The following quantities, positioning and measurements must be observed:
 - 1.5.2.1. Vest:
 - The sponsor advertising is permitted once to be positioned on the front of the vest below the chest level area
 - Maximum 150cm² (one hundred fifty square centimeters).

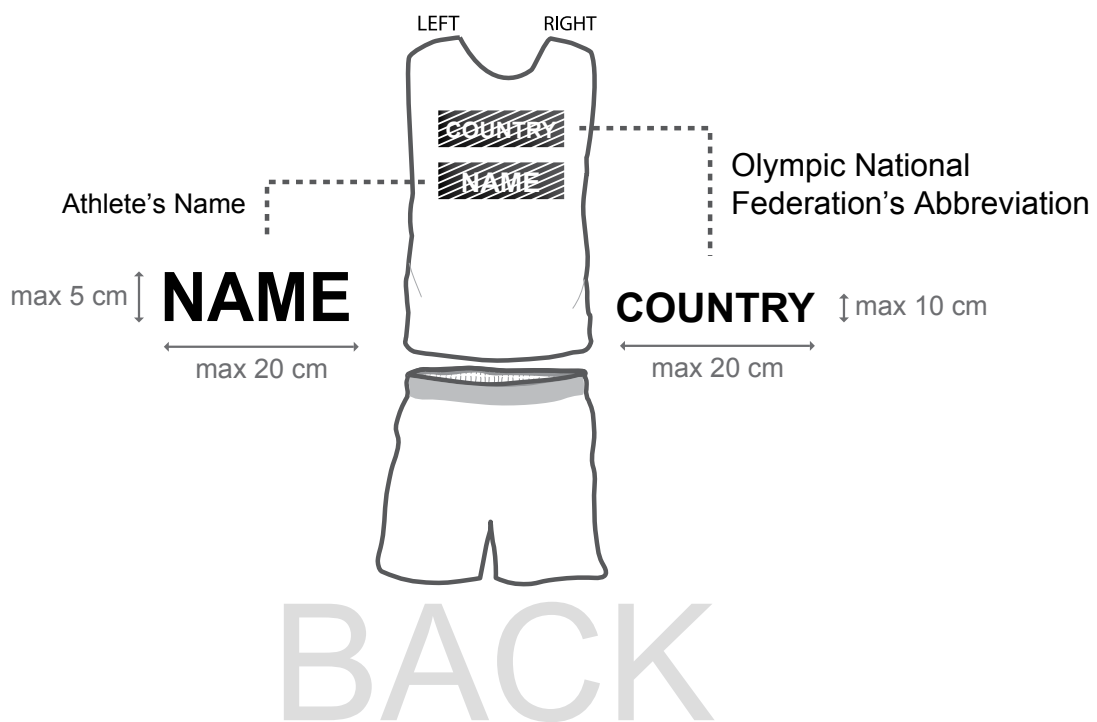
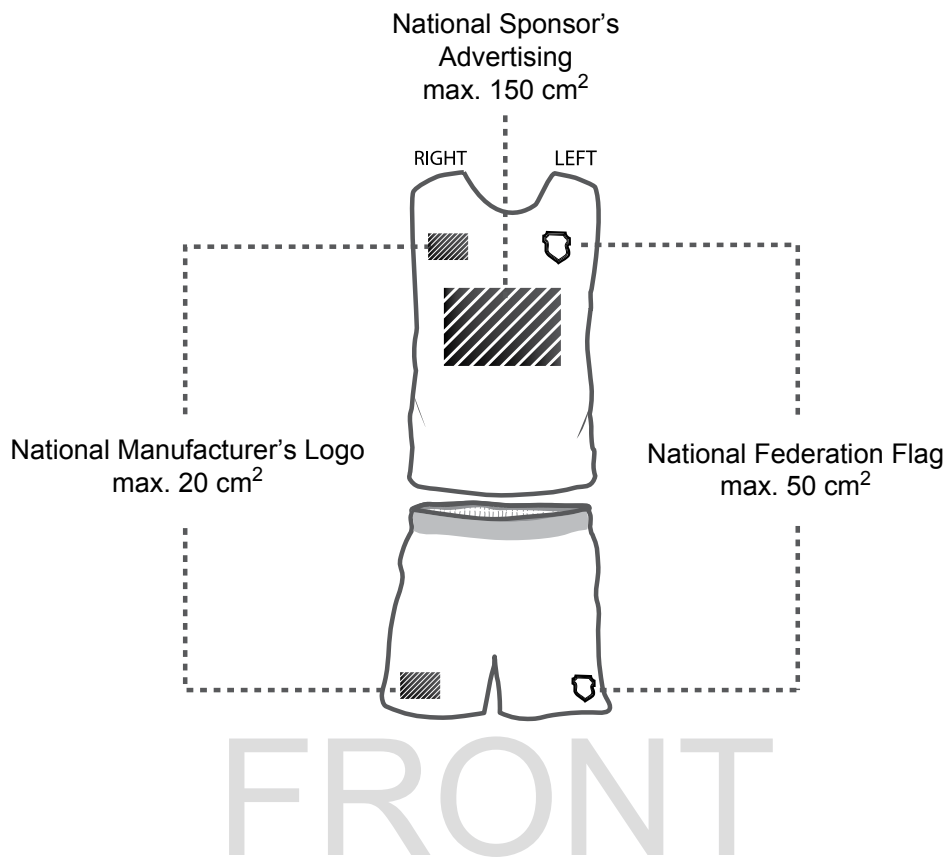

APPENDIX G

AIBA REFEREES & JUDGES (R&J) MANAGEMENT SYSTEM

1. R&J QUALIFICATION MANAGEMENT

1.1. Standard criteria to meet AIBA R&J Fundamental Qualifications

1.1.1. Social Status - The following persons cannot be active R&Js:

- 1.1.1.1. All elected and/or appointed members who are Executives of National Federations such as Presidents, Executive Committee members, Secretaries General, etc.
- 1.1.1.2. Any paid employee of National Federations.
- 1.1.1.3. Active Team Managers, Coaches, Trainers, etc.
- 1.1.1.4. Refereeing & Judging Commission, Technical & Rules Commission and Women's Commission members.

1.1.2. Sport Status:

- 1.1.2.1. The R&Js in the World Series of Boxing can be active R&Js in AIBA and vice versa.
- 1.1.2.2. A person cannot be a Referee only but can be a Judge only.
- 1.1.2.3. Persons from a non-boxing background or former Boxers may become R&Js.

1.1.3. Physical Status:

- 1.1.3.1. All color-blind persons cannot be R&Js.
- 1.1.3.2. A deaf person cannot be a Referee

1.1.4. Ethical Status:

- 1.1.4.1. Any R&J suspended by AIBA for ethical reasons will no longer be accepted for any activity within boxing.

2. R&J QUALITY ENHANCEMENT MANAGEMENT

- 2.1. All R&Js at any level should be trained and judge the competitions only by following the AIBA R&J Manual.
- 2.2. AIBA will certify R&J Instructors to provide the educational seminars and training courses at national and regional levels.
- 2.3. Only AIBA certified R&Js are allowed to officiate in any competition and should be registered in the AIBA Database.

3. R&J CERTIFICATION / CLASSIFICATION MANAGEMENT

3.1. R&J Classification and Certification:

- 3.1.1. AIBA has three levels of international R&Js; in ascending order of seniority: 1-Star, 2-Star and 3-Star. An international R&J's classification is proven by his/her wearing of a certified official AIBA R&J badge with the appropriate number of stars, an official AIBA Record Book and an official diploma provided by AIBA.
- 3.1.2. Section 3.2 below sets out the procedures and processes by which someone becomes a National Referee and progresses to the three international levels. An R&J cannot skip a level.
- 3.1.3. In order to become certified as a 1-Star, 2-Star or 3-Star R&J, applicants must pass a written test and a practical test, as set out in section 3.2 below. In order to stay certified on that level, an R&J must pass in-tournament assessments and the appropriate medical tests.
- 3.1.4. AIBA has two levels of R&J Instructor: National Level and International Level. The AIBA R&J Commission conducts a training and examination course to certify the National and International Level Instructor positions. The AIBA President shall appoint the R&J Instructor who will be assigned for each R&J Examination with the recommendations of the AIBA HQs Office.

3.2. Paths to become an AIBA R&J:

3.2.1. Module 1

- 3.2.1.1. The candidate should be given the introductory booklet two to three weeks before the Induction Examination. This booklet covers the Rules the candidate should know to begin the first stage.
- 3.2.1.2. The Induction Process should commence with a four hour clinic, 2 x 2 hour sessions, covering all the topics in the exam paper and conducted by a National Federation certified R&J Trainer.
- 3.2.1.3. On successful completion of the Induction Period and the examination paper, the candidate will have demonstrated a sufficient knowledge of the Rules to advance to Module 2.
- 3.2.1.4. AIBA Officials Induction Clinic – Judges

The purpose of the session is to prepare the candidates to become qualified National Level Judges and to familiarize them with and have them understand the Rules that will help them providing Boxers with fair and consistent rulings.

3.2.2. Module 2

- 3.2.2.1. The candidate should be assigned to a “mentor” (an already qualified AIBA Official in good standing) who will supervise progress throughout Module 2.
- 3.2.2.2. The first stage is to spend at least ten contests working with a certified Timekeeper; five as the Assistant Timekeeper then five as the Timekeeper under the supervision of the certified Timekeeper.
- 3.2.2.3. This complete module gains practical experience of the three areas required to work in or around the ring thus refereeing, judging and an appreciation of timekeeping.
- 3.2.2.4. The second stage will see the candidate introduced to actual contests as a “Supernumerary Judge” using either the AIBA Scoring System or a handheld scoring machine or clicker device.

3.2.2.5. The candidate should score at least 30 contests under the supervision and critique of the candidate's mentor.

3.2.2.6. Having completed the above, the candidate will, with the approval of the candidate's mentor, advance to the next Module.

3.2.3. Module 3

3.2.3.1. This stage will necessitate some practice as a Referee in gymnasium sparring sessions.

3.2.3.2. This can usually be arranged in a number of ways, such as:

- In sessions arranged by the National Federation
- In a facility arranged and approved by the candidate's mentor
- In a boxing club to which the candidate is registered.

3.2.3.3. When the candidate is considered as being ready, the candidate should be introduced as a Referee in junior contests and complete successfully at least 30 bouts, again under the management and critique of the candidate's mentor.

3.2.3.4. During this time, the candidate will also undoubtedly have completed numerous bouts as a Judge and, on the recommendation of the candidate's mentor, should then be approved to National Level.

3.2.4. Module 4 - National Level

3.2.4.1. National level is where the candidate can operate at all levels within the National Federation and should accomplish the following recommended minimum parameters:

- Judge 50 contests
- Referee 30 contests
- Both of the above should include at least one National Elite Championships.

3.2.4.2. When all of the above has been completed with an acceptable level of competency, the candidate can be recommended by the National Federation certified R&J Trainer for the AIBA Entrance Examination.

3.2.5. Module 5 - AIBA 1-Star R&J

3.2.5.1. Candidates for admission to the lists of AIBA Referees & Judges cannot be Executive members or paid employees of the National Federations.

3.2.5.2. The AIBA Entrance Examination can be arranged by the candidate's National Federation or the candidate can attend an examination being hosted by another National Federation or quite possibly at the AIBA Boxing Academy.

3.2.5.3. The AIBA Entrance Examination will consist of four parts:

- An extensive questionnaire examination paper covering AIBA Technical & Competition Rules
- An oral examination to clarify that the candidate understands these Rules
- Judge at least ten contests in a competition
- Referee at least five contests in a competition.

3.2.5.4. The Candidate must demonstrate total competency in all the segments of the examination to be accredited as an AIBA 1-Star R&J. Should the candidate demonstrate an exceptional talent to the examiners during the examination, the candidate could be invited to attend a course at the AIBA Boxing Academy

which, if completed to a very high standard, could fast track the candidate to an AIBA 3-Star R&J status.

3.2.5.5. Eligibility:

- Challenge Matches
- Designated Multi-Nation Tournaments (for a 2-Star Assessment).

3.2.6. Module 6 - AIBA 2-Star R&J

3.2.6.1. Eligibility:

- All Multi-Nation Tournaments
- Designated Multi-Nation Tournament (for a 3-Star Assessment).

3.2.7. Module 7 - AIBA 3-Star R&J

3.2.7.1. As this is the highest grade an AIBA R&J can obtain, it is awarded to only the very best Officials who have continually demonstrated their high standards in judging and refereeing and successfully completed to a high degree of competency the AIBA Boxing Academy's Workshop / Examination.

3.2.7.2. Eligibility:

1. Olympic Games, Youth Olympic Games, Olympic Qualifying Events
2. All AIBA World Championships
3. Commonwealth Games, Asian Games, Pan-American Games, African Games
4. Continental Championships
5. World Cup
6. President's Cup
7. Approved Multi-Sport Games

3.2.7.3. AIBA R&J 2- and 3-Star status is performance maintained and any lowering of standards or questionable performance by the holder may result in a recommended downgrade.

3.2.7.4. It is also possible that an AIBA R&J who is considered incompetent may have his/her AIBA R&J status revoked completely.

3.2.7.5. AIBA R&Js and indeed all members of the AIBA Family are expected to conduct themselves in a manner that will never bring AIBA into disrepute.

3.3. R&J Test Procedure

3.3.1. 1-Star Test

3.3.1.1. When a National Federation determines to test members for admission to the lists of AIBA 1-Star R&Js, it should adopt the following procedure:

- Make an application to the AIBA HQs Office along with give full details of tournament, venue, dates, etc.
- Complete a Test Application Form for each candidate and forward all to the AIBA HQs Office
- Transfer the appropriate test fees (US\$ 100 per applicant) to AIBA's bank account

- The AIBA HQs Office shall approve or deny the request from the National Federation with the recommendation of the AIBA R&J Commission Chairman.
- Once such Examination is approved, the AIBA President shall appoint the Examination Commission consisting of two members with the recommendations of the AIBA HQs Office:
 - A qualified International Level R&J Instructor from a different country than the host
 - A qualified National Level R&J Instructor from a different country than the host and the International Level R&J Instructor
- The Examination Commission will inform the AIBA HQs Office of the examinations' results
- The AIBA HQs Office shall relay results to the AIBA R&J Commission and the National Federation concerned and forward all appropriate certificates.

3.3.2. Graduation to 2- or 3-Star

3.3.2.1. The AIBA R&J Commission, with the approval of the AIBA Executive Committee, will designate Multi-Nation Tournaments in all continents where 1-Star R&Js can be assessed for promotion to a 2- or 3-Star R&J status using the following procedure:

- All National Federations will be informed of the tournaments where the AIBA R&J Commission appointed personnel will be present to assess 1-Star R&Js for graduation to a 2-Star R&J status and 2-Star R&J for graduation to a 3-Star R&J status.

Examiners / Instructors will be appointed and all other notifications shall be according to Rule 3.3.1.

3.4. Validity of Test Period

- 3.4.1. The AIBA R&J certification is valid for a period of four years from its commencement and after that period, the Official or respective National Federation must arrange for a control test.
- 3.4.2. Should an R&J officiate successfully at any major AIBA Event, Olympic Games, etc., then the validity period of the license will be extended to four years from the date of that event.

4. R&J APPOINTMENT MANAGEMENT FOR COMPETITIONS

- 4.1. For all AIBA Approved and Controlled Events, the AIBA R&J Commission will prepare a list of suitably qualified Officials and present the names to the AIBA President for his approval.
- 4.2. For all Confederation Events, the Confederation R&J Commission will prepare a list of suitably qualified Officials and present the names to the Confederation President for his approval.
- 4.3. For major events, a Captain of R&Js should be nominated:
 - 4.3.1. To be the leader in the R&J group
 - 4.3.2. To be the spokesperson of the R&J group
 - 4.3.3. To be the chaperon / liaison person for the R&J group
- 4.4. Whenever AIBA is responsible for R&J costs, it should cover the following:

- 4.4.1. Complete travel costs
 - 4.4.2. Accommodation / meals
 - 4.4.3. Visa fee
 - 4.4.4. Per Diem
 - 4.4.5. Certification diploma and evaluation (but not if suspended or removed).
- 4.5. Approved Events to be covered by AIBA:
- 4.5.1. Olympic Qualifying Events
 - 4.5.2. World Championships
 - 4.5.3. Continental Championships
 - 4.5.4. World Cup
 - 4.5.5. President's Cup
- 4.6. Number of R&Js in Each Event
- 4.6.1. AIBA Controlled Events:
- For all AIBA Controlled Events, AIBA shall assign only one (1) R&J from each country except in the World Championships where a maximum of two (2) R&Js are permitted for the host country.
- 4.6.2. AIBA Approved Events:
- For all AIBA Approved Events including all Confederation Events, each participating country may send only one (1) R&J and the Organizing Committee must request for neutral R&Js from either AIBA or the Confederation from non-participating or non-continental countries other than the host continent in case there is not enough R&Js for the event.
- In any circumstance, only 1 R&J per country per event shall be authorized. However, a maximum of 2 R&Js is permitted for the host country.
- 4.7. Confirmation of the Eligibility in Each Event
- 4.7.1 For all AIBA Approved Events including all Confederation Events, the LOC shall send the registered R&Js from each National Federation to the AIBA HQs Office to receive its final confirmation on the R&Js' eligibility to participate in the event, this before the start of the competition.

5. R&J PERFORMANCE MANAGEMENT – R&J EVALUATION

- 5.1. Computerized evaluation data shall be made available to appointed Judges' Evaluators and the Competition Jury who shall use this data as part of their evaluation.
- 5.1.1 For AIBA Controlled Events:
- 5.1.1.1 There will be assigned Judges Evaluators
 - 5.1.1.2 The Competition Jury members will concentrate on an evaluation of Referees only during the competition

5.1.1.3 Both Evaluators and the Competition Jury members will submit their evaluation results to the Technical Delegate to manage the performance and selection of R&Js for the bouts

5.1.2 For other events:

5.1.2.1 The Competition Jury members will evaluate the performance of both Referees and Judges during the competition and to submit the results to the Technical Delegate

5.1.2.2 Time protocol sheets will only be available if requested by the Technical Delegate assigned R&J Evaluators.

6. R&J IN-COMPETITION MANAGEMENT

6.1. Unification of R&Js must be done before the start of each international event by the organization of a mandatory one full day seminar conducted by a designated AIBA R&J Instructor.

6.2. R&J Meeting / Assessments

6.2.1. Each day, the contest sheets of the previous day should be displayed by the Chairperson of the Competition Jury at least 10 minutes before the start of the R&J Meeting and mistakes should be highlighted.

6.2.2. R&Js should not be able to take the contest sheets.

6.2.3. The R&J Meeting should be conducted by the Chairperson of the Competition Jury.

6.2.4. For other events, the R&J Meeting should be conducted by the Technical Delegate.

6.2.5. Under no circumstances will the Technical Delegate endorse an R&J Record Book with an opinion of performance at a tournament – The Technical Delegate shall specify the number of bouts officiated by each R&J.

6.3. The R&J Lounge

6.3.1. The R&Js' lounge and meeting room should be comfortable, have proper chairs and tables and should be clean.

6.3.2. The lounge should be checked and approved by the Technical Delegate before the event to satisfy the requirements.

6.4. Hotel Accommodation

6.4.1. The R&Js' hotel should be separate from the Team Delegations' hotel but could be the same as the AIBA Family and ITOs.

6.5. Accreditation – Access Zone Definition

6.5.1. R&Js should only get access to the Field of Play and R&J Lounge.

6.6. Dress Code

6.6.1. All R&Js in AIBA Approved Events shall wear uniforms provided by AIBA.

6.7. Code of Conduct

6.7.1. AIBA R&J Code of Conduct should be signed for all events by participating R&Js.

7. R&J DATABASE MANAGEMENT

7.1. AIBA R&J Database Maintenance

- 7.1.1. The AIBA HQs Office maintains all records of R&Js on their participation, evaluation and personal information.
- 7.1.2. Except the performance evaluation, all information shall be available to the public.

7.2. AIBA Commission Members

- 7.2.1. Membership to AIBA and Confederation R&J Commissions is restricted to persons who were active on the AIBA R&J lists with a 3-Star status.
- 7.2.2. Membership to the AIBA R&J Commission is further restricted to candidates who have served at least two years on their Confederation R&J Commission.
- 7.2.3. Active AIBA R&Js cannot be members of R&J Commissions at any level.
- 7.2.4. Confederation R&J Commission Chairpersons should be part of the AIBA R&J Commission.
- 7.2.5. All applicants must have the support of their respective National Federation.
- 7.2.6. All applications for membership to the AIBA or Confederation R&J Commissions should be submitted to the AIBA or Confederation HQs Office at least three months before the respective Congress.

8. WSB R&J MANAGEMENT

8.1. Eligibility

- 8.1.1. All internationally qualified AIBA R&Js shall be able to apply to be WSB R&Js.
- 8.1.2. R&Js who have officiated as R&Js in non-AIBA professional boxing are eligible to become WSB R&Js provided that, from the moment of their acceptance, they no longer officiate in non-AIBA professional boxing.

APPENDIX H

RING SPECIFICATIONS AND GUIDELINES

1. THE RING AND ACCESSORIES

1.1. Canvas Size

- 1.1.1. For AIBA Approved Events, the competition ring shall be 6.10m squared (20 feet) inside the line of the ropes.
- 1.1.2. For other events, the minimum size of the inside of the ropes shall be 4.90m squared (16 feet) and the maximum size – 6.10m squared (20 feet).
- 1.1.3. The size of the apron shall extend for 85cm (33.5 inches) outside the line of the ropes on each side for all AIBA Approved Events and at least 46cm (18 inches) outside the line of the ropes on each side for all other competitions, including additional canvas necessary to tighten and secure it.

1.2. Height of Ring

- 1.2.1. For AIBA Approved Events, the height of the ring should be 100cm (3.3 feet) from the ground.
- 1.2.2. For other events, the competition ring shall not be less than 91cm (3 feet) or more than 1.22m (4 feet) above the ground or base.

1.3. Platform and Corner Pads

- 1.3.1. The platform shall be safely constructed, leveled and free from any obstructing projections.
- 1.3.2. For AIBA Approved Events, the platform shall be 7.80m squared (25.6 feet)
- 1.3.3. For other events, the minimum size of the platform shall be 5.82m squared (19.1 feet) and the maximum size – 7.80m squared (25.6 feet)
- 1.3.4. It shall be fitted with four corner posts which shall be well padded or otherwise constructed so as to prevent injury to the Boxers.
- 1.3.5. The corner pads should be arranged in the following way: In the near left-side corner facing the Chairperson of the Competition Jury – red; in the far left side corner - white; in the far right-side corner - blue; and in the near right-side corner - white.

1.4. Surface of Ring Floor

- 1.4.1. The floor shall be covered with felt, rubber or other suitably approved material having the same quality of elasticity and not less than 1.3cm (half an inch) nor more than 1.9cm (three quarters of an inch) thick over which a canvas shall be stretched and secured in place.
- 1.4.2. The canvas shall cover the entire platform and shall be made of non-slippery material.

1.5. Ropes

- 1.5.1. All AIBA Approved Events should have 4 separate ropes on each side of the ring. They should be 4cm thick, without considering the cover.
- 1.5.2. The height of the 4 ropes shall be 40.6cm (16 inches), 71.1cm (28 inches), 101.6cm (40 inches) and 132.1cm (52 inches) from the canvas.

- 1.5.3. The 4 ropes shall be joined on each side of the ring, at equal intervals, by two pieces of material (close to the texture of the canvas) 3 to 4cm (1.2-1.6 inches) wide. The two pieces must not slide along the rope.
 - 1.5.4. The tension of each section of the rope shall be strong enough to absorb the impact of the Boxer's contact with the rope. However, in any case, the Referee reserves the right to adjust the tension if necessary.
- 1.6. Steps
- 1.6.1. The ring shall be provided with three sets of steps. Two sets of steps at the opposite corners for the use of the Boxers and Seconds, and one set of steps in the neutral corner for the use of the Referees and Doctors.
- 1.7. Sanitary Bags
- 1.7.1. In the two neutral corners outside of the ring, a small plastic bag shall be fixed in each corner in which the Medical Jury, Doctors or Referees shall drop the cotton or tissue pads used to nurse bleedings.
- 1.8. Approved Label
- 1.8.1. For all AIBA Approved Events, the Organizing Committee should use the rings manufactured by one of the AIBA Official Licensees.
 - 1.8.2. All existing rings can be used until 2010. However, after 2010, for all AIBA Approved Events, a new ring with AIBA approved labels must be used.

2. ACCESSORIES OF THE RINGSIDE

- 2.1. The following are defined as the accessories of the ringside which are required for all AIBA Approved Events:
- 2.1.1. Gong (with striker) or bell. In the case of two (2) competition rings, one ring is to have a gong and the other ring is to have a bell with two distinctive sounds.
 - 2.1.2. Two seats for Boxers' use during intervals.
 - 2.1.3. Two plastic mugs can to be used for drinking and mouth wash only, and where water is not piped directly to the ringside, two plastic spray bottles and two small plastic bottles for drinking. No other type of water bottle is permitted at ringside for use by the Boxers or seconds.
 - 2.1.4. Tables and chairs for officials.
 - 2.1.5. One (preferably two) stop watches.
 - 2.1.6. One first-aid kit.
 - 2.1.7. One microphone connected to the loudspeaker system.
 - 2.1.8. Two (2) pairs of competition gloves (one in red and one in blue color).
 - 2.1.9. One stretcher.
 - 2.1.10. Two (2) headguards (one in red and one in blue color).

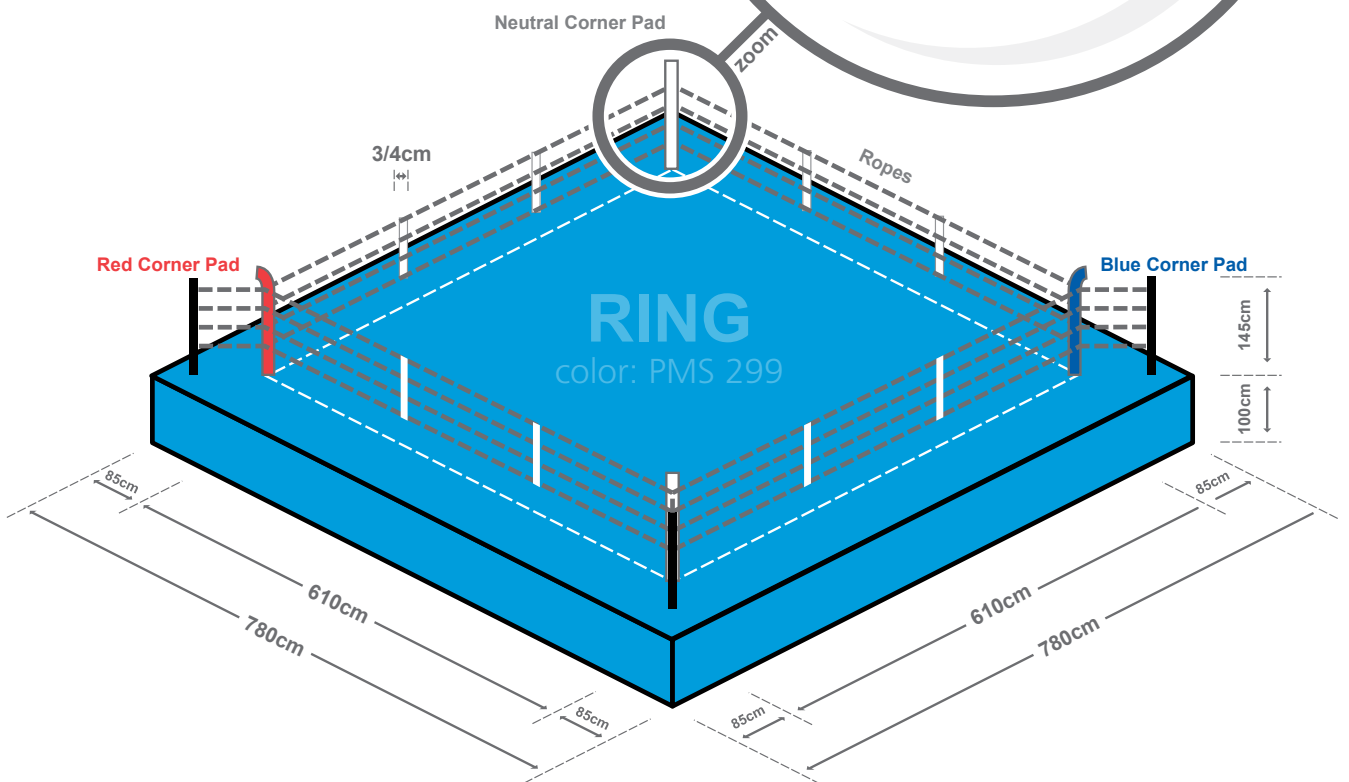
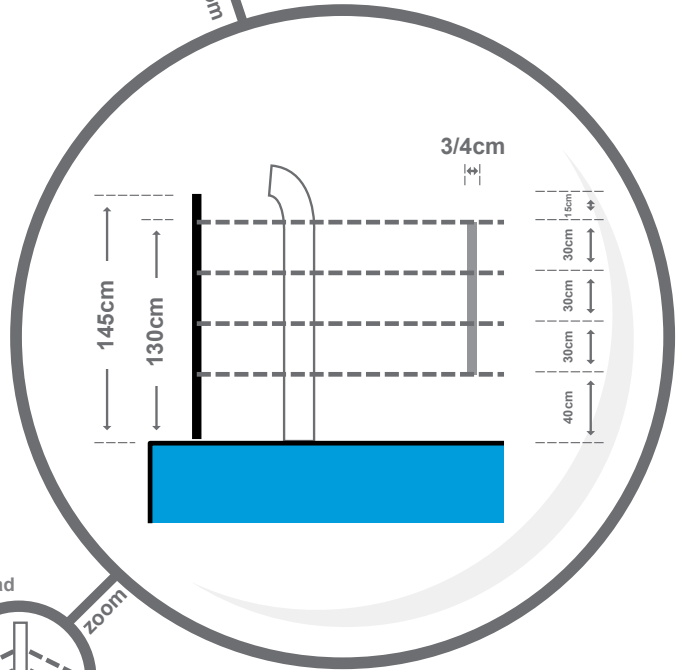
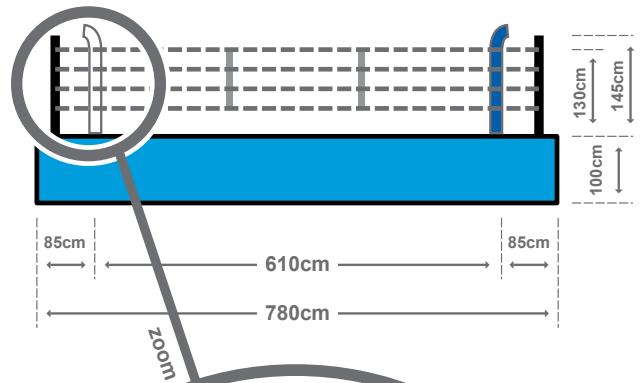
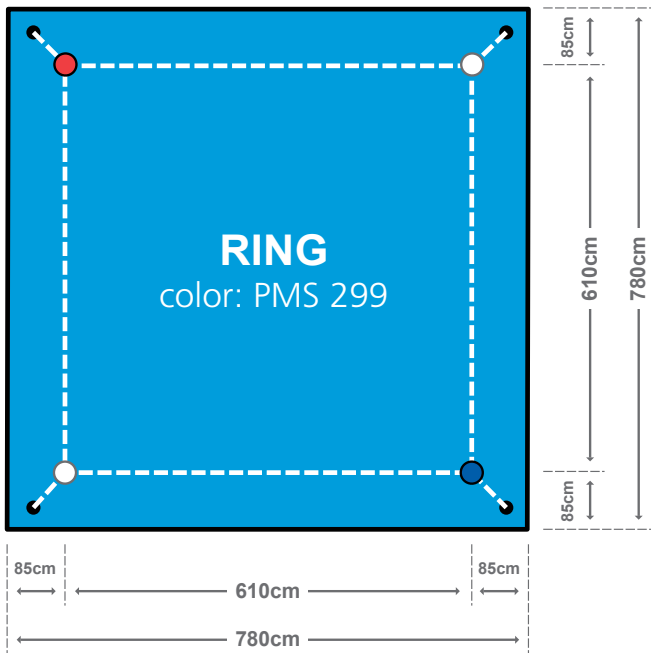

APPENDIX I FIELD OF PLAY (FOP) MANAGEMENT

1. FOP FORMATION OF ONE RING

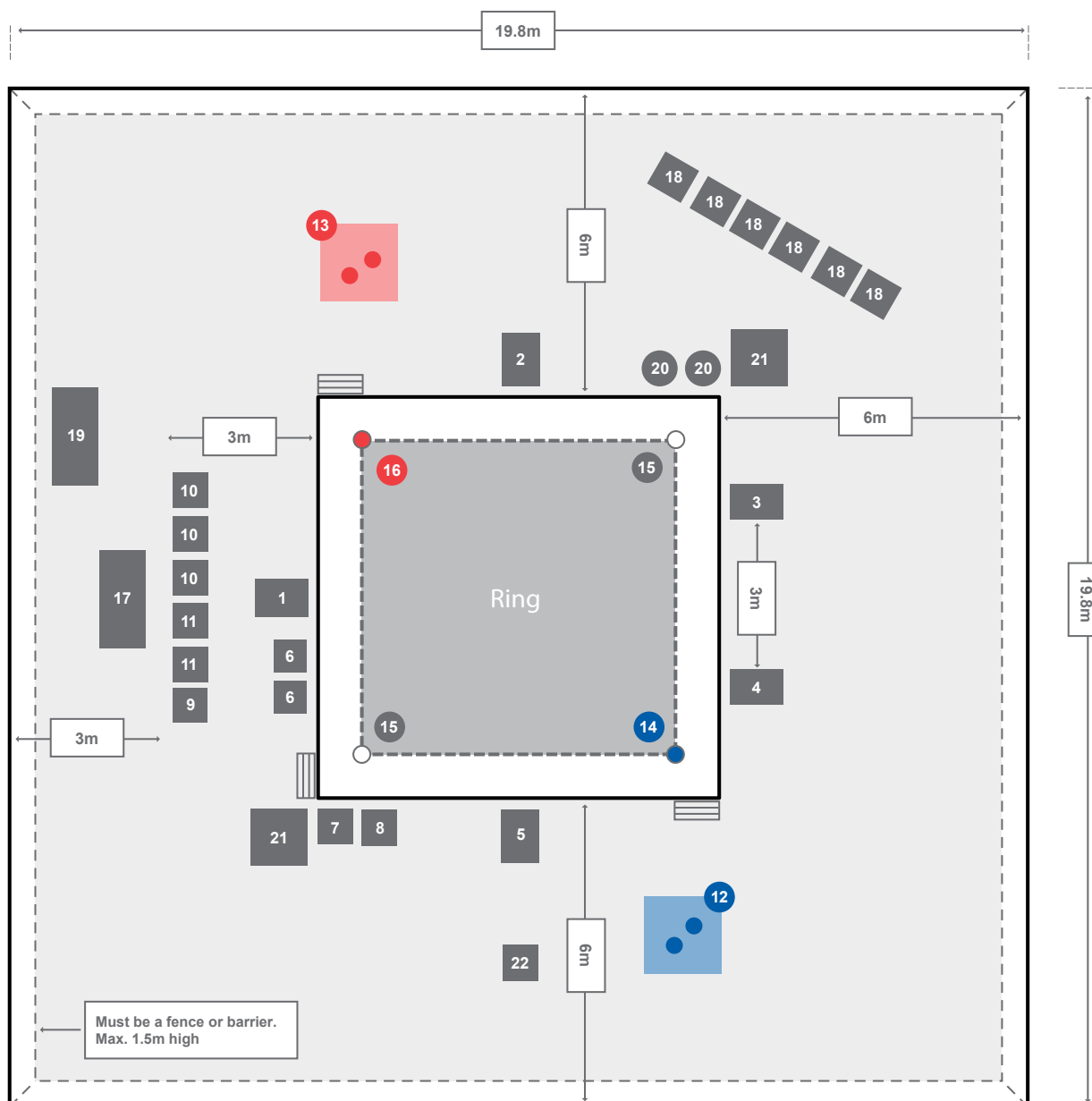

1. Judge Position #1
2. Judge Position #2
3. Judge Position #3
4. Judge Position #4
5. Judge Position #5
6. Medical Jury Table
7. Timekeeper
8. Gong Operator
9. Announcer
10. Competition Jury
11. Scoring System Operator

12. Blue Seconds Seating Area
13. Red Seconds Seating Area
14. Blue Corner
15. Neutral Corner
16. Red Corner
17. Technical Delegates
18. Standby R&Js
19. Draw Commission
20. Photographers
21. T.V. Camera stand
22. Judges' Evaluator

2. FOP FORMATION OF TWO RINGS

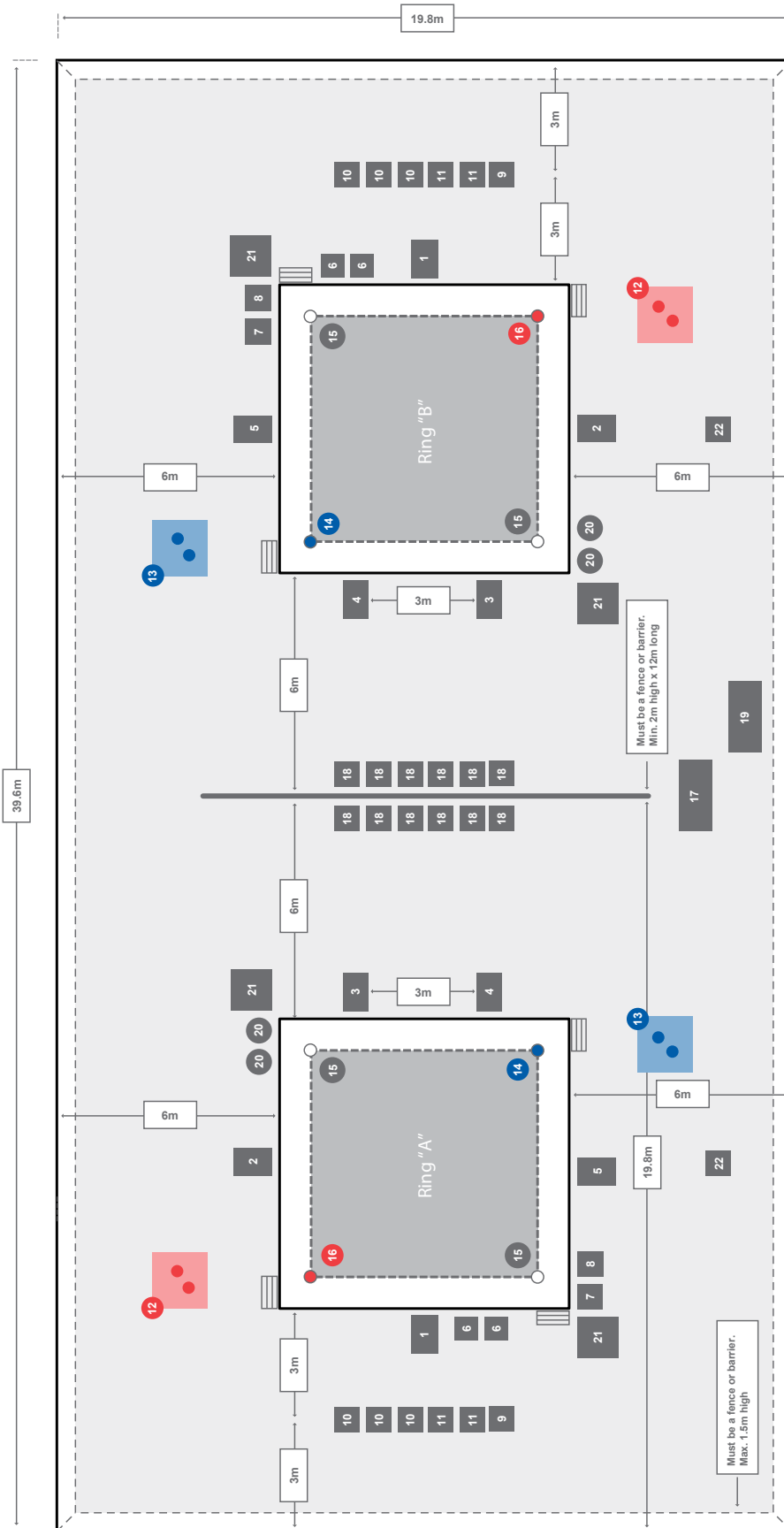

1. Judge Position #1
2. Judge Position #2
3. Judge Position #3
4. Judge Position #4
5. Judge Position #5
6. Medical Jury Table
7. Timekeeper
8. Gong Operator
9. Announcer
10. Competition Jury
11. Scoring System Operator

12. Red Seconds Seating Area
13. Blue Seconds Seating Area
14. Blue Corner
15. Neutral Corner
16. Red Corner
17. Technical Delegates
18. Standby R&Js
19. Draw Commission
20. Photographers
21. T.V. Camera stand
22. Judges' Evaluators

3. DUTIES OF AND GUIDELINES FOR THE COMPETITION MANAGER

- 3.1. To oversee the running of the competition and to be the focal person for AIBA to contact in relation to competition issues.
- 3.2. To ensure that the competition is organized and conducted in accordance with the AIBA Technical & Competition Rules under the guidance of the Technical Delegate(s).
- 3.3. To liaise with other functional areas to ensure a coordinated delivery of support services such as accreditation, security, transport, medical, media, venue operations, venues, host broadcaster and volunteers.
- 3.4. To liaise regularly with the Technical Delegate(s), the Host National Federation and the Organizing Committee on matters relating to the preparation of the competition.
- 3.5. To report to AIBA and the Technical Delegate on a regular basis on the preparation of the event.
- 3.6. To establish a list of equipment required for the boxing competition.
- 3.7. To provide a specific sport input into venue planning and operations for all competition and training sites.
- 3.8. To recommend an appropriate organizational structure and appropriate staffing levels for the conduct of the competition.
- 3.9. To train and manage staff and volunteers on a day-to-day basis.
- 3.10. To collaborate with the Host National Federation and Organizing Committee regarding the selection and training of the National Technical Officials.
- 3.11. To organize and conduct orientation and briefing sessions for all staff, technical officials, and volunteers prior to the commencement of the competition.
- 3.12. To ensure all assets of the Organizing Committee assigned to an area are properly secured and maintained.
- 3.13. To ensure all policies and procedures of the Organizing Committee are followed, venue emergency procedures are in place and related issues (e.g. discipline, security, working conditions, etc.) are properly enforced, documented and irregularities reported.
- 3.14. To attend such meetings and undertake such liaison as may be necessary as Competition Manager, reporting and taking action as required.

4. ITO POSITIONS IN AND AROUND THE FOP

- 4.1. The R&J Coordinator shall be placed in the same area as the Draw Commission, but, for the avoidance of possible interference, not immediately next to the Draw Commission.
- 4.2. The Equipment Manager's table shall be located at the Boxers' entrance to the FOP.
- 4.3. The International Competition Record Book Management shall be done at the table located nearby the Boxers' exit from the FOP.
- 4.4. A table for AIBA shall be located close to the Technical Delegate and/or Draw Commission tables.

5. MEDIA GUIDELINES

- 5.1. If a platform for TV cameras is required during a competition, its length and width shall each be of 1 meter. Its height shall be determined jointly by the TV production organization and the Competition Manager, subject to the Technical Delegate's approval.
- 5.2. TV Camera Operators are only allowed to move around the ring's apron during breaks between rounds and between bouts.
- 5.3. Each Camera Operator may have one assistant at the maximum, and this assistant must remain on the floor.
- 5.4. No more than four (4) photographers may be positioned at ringside during competition. They are to remain in a marked area of 1.5 meters from the neutral corner towards Judge 2.
- 5.5. Only at the end of a bout are photographers allowed to move around the ring, with the exception of the side where the Competition Jury is located.
- 5.6. Microphones may only be attached to the backside of the pads in the neutral corners.

APPENDIX J

GLOVE AND HEADGUARD SPECIFICATIONS AND GUIDELINES

1. GLOVES

- 1.1. Boxing gloves shall weigh 284 grams (approx. 10 oz), with a tolerance of 5% up or downwards, of which the leather portion shall not weigh more than half of the total weight, and the padding portion shall not weigh less than half of the total weight. The margin of 5% would also apply downwards and upwards, respectively.
- 1.2. The size of the boxing gloves shall respect the measurements as described in the graphic below.
- 1.3. Only boxing gloves with Velcro closing systems shall be approved for all AIBA Approved Events.
- 1.4. The leather portion of the boxing gloves shall be made of high quality leather such as
 - 1.4.1. Cowhide leather.
 - 1.4.2. Grade A leather.
 - 1.4.3. Others of equivalent quality subject to AIBA's approval.
- 1.5. The thumb should be fixed to the main body of the boxing gloves by the top part and with a maximum gap of 10 millimeters.
- 1.6. The event identification may be printed and may be displayed at the following positioning and measurements:
 - 1.6.1. Maximum 50cm² (fifty square centimeters) on the front top part of each glove.
- 1.7. The official supplier's logo may be printed and may be displayed at the following positioning and measurements:
 - 1.7.1. Maximum 50cm² (fifty square centimeters) on the wrist of each glove.
- 1.8. Any other form of advertising shall be prohibited such as and non limited to figurative logo, design mark, script and manufacturer name, etc.
- 1.9. The AIBA label should be placed on the internal part of the gloves.

2. HEADGUARDS

- 2.1. Headguards shall weigh a maximum of 450 grams (approx. 16 oz).
- 2.2. Headguards shall be allowed in competition in 3 mandatory sizes (S=Small, M=Medium, L=Large).
- 2.3. Only headguards with Velcro closing systems shall be approved for all AIBA Approved Events.
- 2.4. The measurements of the headguards shall respect the dimension as described in the graphic below.
- 2.5. The padding of the headguards shall respect a minimum thickness of 2cm to 3,5cm

- 2.6. The leather portion of the headguards shall be made of high quality leather such as:
- 2.6.1. Cowhide leather.
 - 2.6.2. Grade A leather.
 - 2.6.3. Others of equivalent quality subject to AIBA's approval.
- 2.7. The event identification may be printed and may be displayed at the following positioning and measurements:
- 2.7.1. Maximum 50cm² (fifty square centimeters) on the front part of the headguards.
- 2.8. The official supplier's logo may be printed and may be displayed at the following positioning and measurements:
- 2.8.1. Maximum 40cm² (forty square cm) on the back part of the headguards.
- 2.9. Any other form of advertising shall be prohibited such as and non limited to figurative logo, design mark, script, manufacturer name, etc.
- 2.10 The AIBA label should be placed on the internal part of the headguards.

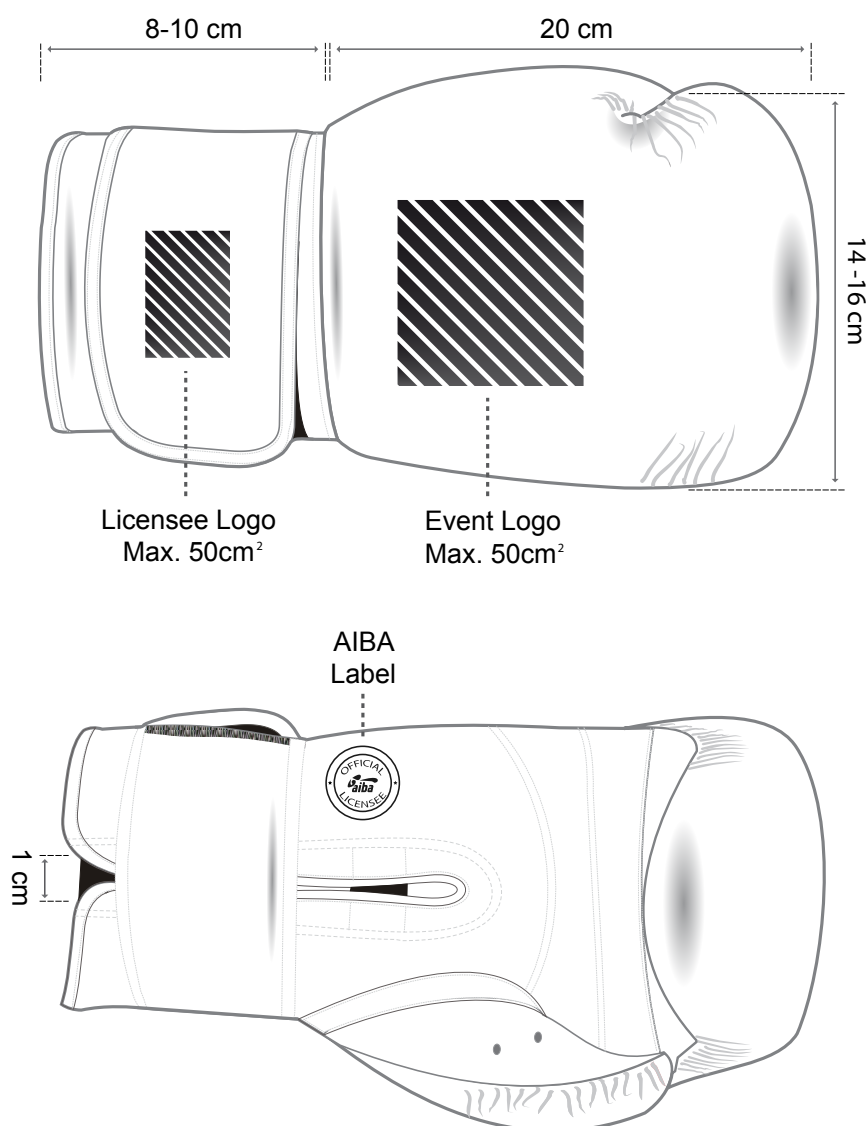

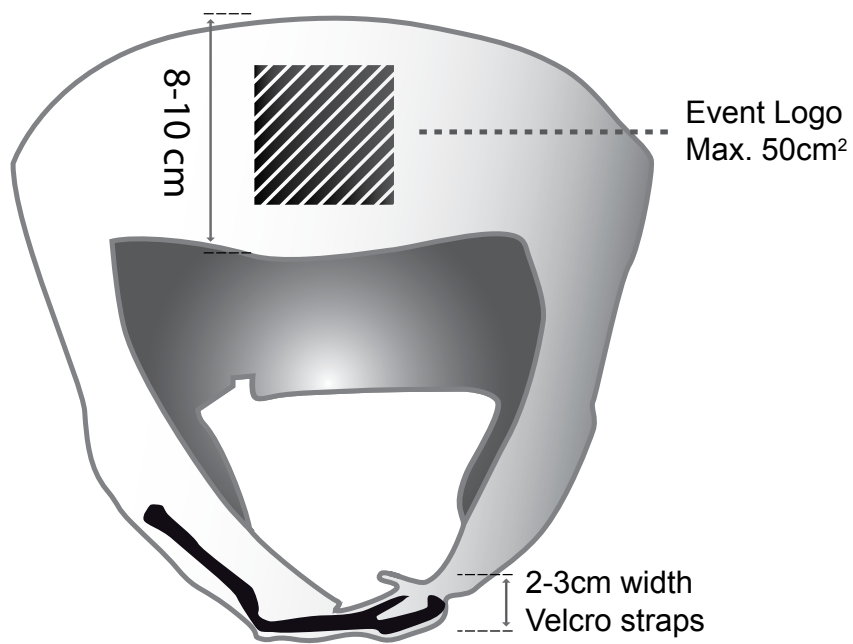

FRONT

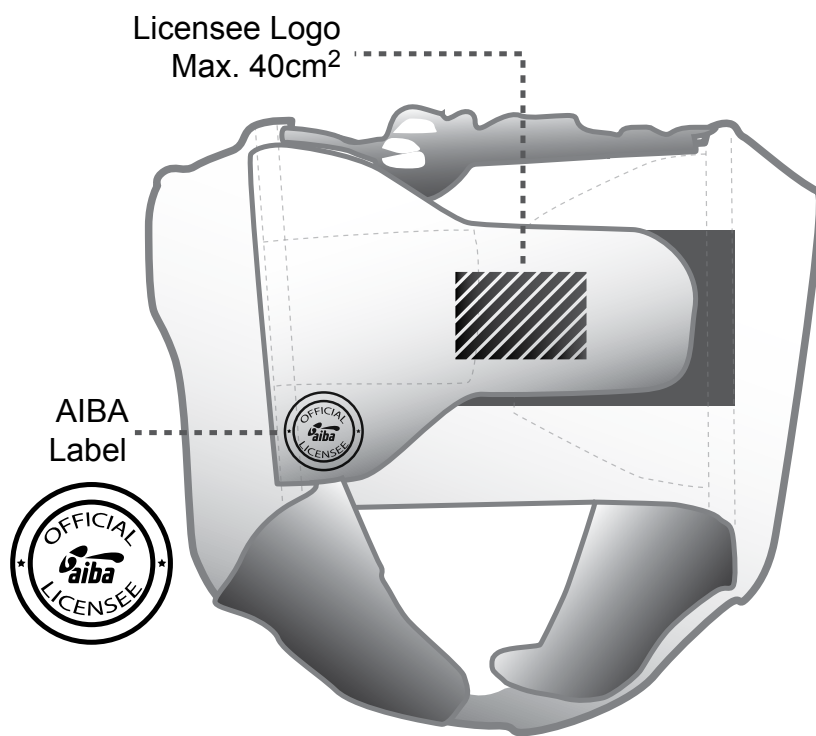

BACK

APPENDIX K

TERMINOLOGY FOR WEIGHT CATEGORIES AND WEIGHT RANGE

Elite Men and Youth Boy Boxers 10 Weight Categories (from September 1, 2010)		
Weight Category	over kg	to Kg
Light Fly	46	49
Fly	49	52
Bantam	52	56
Light	56	60
Light Welter	60	64
Welter	64	69
Middle	69	75
Light Heavy	75	81
Heavy	81	91
Super Heavy	91	-

Olympic Games Elite Women and Youth Girls Boxers 3 Weight Categories		
Weight Category	over kg	to Kg
Fly	48	51
Light	57	60
Middle	69	75

Elite Women and Youth Girls Boxers 10 Weight Categories (from September 1, 2010)		
Weight Category	over kg	to Kg
Light Fly	45	48
Fly	48	51
Bantam	51	54
Feather	54	57
Light	57	60
Light Welter	60	64
Welter	64	69
Middle	69	75
Light Heavy	75	81
Heavy	81	-

Junior Boys and Junior Girls Boxers 13 Weight Categories		
Weight Category	over kg	to Kg
Pin	44	46
Light Fly	46	48
Fly	48	50
Light Bantam	50	52
Bantam	52	54
Feather	54	57
Light	57	60
Light Welter	60	63
Welter	63	66
Light Middle	66	70
Middle	70	75
Light Heavy	75	80
Heavy	80	-

APPENDIX L

AIBA SCORING SYSTEM

1. KEY FEATURES OF SCORING SYSTEM

- 1.1. The scoring system is based on the Individual Score.
- 1.2. There is no “one second window” for three Judges to score at the same time.
- 1.3. No running score during the bout, only running time.
- 1.4. Individual Scores of each Judge are displayed during the break.
- 1.5. No computerized Judges’ evaluation.

2. SCORING METHOD

- 2.1. Per round, each Individual Score is counted.
- 2.2. The scores in each round are the average of three Judges’ score combination which are the closest together called as Similar Scores.
- 2.3. For each round, the results of the Individual Scores are calculated separately for the red Boxer and the blue Boxer.
- 2.4. If at the end of a round more than one Similar Score appears, the Trimmed Mean calculation will apply. The Trimmed Mean is when the highest and lowest Individual Scores are taken out and the average of the remaining three Individual Scores is counted.

3. WARNING

- 3.1 Warnings are not linked to the Individual Scores but considered with 2 points awarded to the opponent in the Total Score.

4. DECISIONS

- 4.1 The Winner is the Boxer with the highest Total Score.
- 4.2 In case of a tie in the Final Scores:
 - 4.2.1. First, delete the lowest and highest Judges’ total scores in each red and blue corner. Then, the winner will be determined by the total scores of the remaining three Judges of each red and blue corner.
 - 4.2.1. Second, in case of a tie after the above process, all five (5) Judges shall be asked to press the button once for the Boxer who has won. The decision is made by the majority of the panel of these five (5) Judges.

5. DISPLAY OF THE SCORING SYSTEM

5.1 The following display will be shown during the first round

Coach Online Scoreboard									
During Bout									
Ring A		48kg		Bout: 1					
NOC code Boxers Name		R1		NOC					
		0:02		code		Boxers Name			
Scores									
Warnings		Round:		R1		R2		R3	
1	1	Score:							

5.2 The following display will be shown during the first break after the first round

Coach Online Scoreboard									
During Bout									
Ring A		48kg		Bout: 1					
NOC code 6		B1		7					
		0:02		code		NOC			
J1		J2		J3		J4		J5	
3	5	5	3	2	2	4	4	4	5
Scores									
Warnings		Round:		R1		R2		R3	
1	1	Score:		6	7				

5.3 The following display will be shown during the second round

Coach Online Scoreboard									
During Bout									
Ring A		48kg		Bout: 1					
NOC code Boxers Name		R2		NOC					
		0:02		code		Boxers Name			
Scores									
Warnings		Round:		R1		R2		R3	
1	1	Score:		6	7				

5.4 The following display will be shown during the second break after the second round

Coach Online Scoreboard									
During Bout									
Ring A		48kg		Bout: 1					
NOC code 10		B2		13					
		0:02		code		NOC			
J1		J2		J3		J4		J5	
4	3	3	4	4	4	3	3	4	4
Scores									
Warnings		Round:		R1		R2		R3	
2	1	Score:		6	7	4	6		

5.5 The following display will be shown during the third round

Coach Online Scoreboard									
During Bout									
Ring A		48kg		Bout: 1					
NOC code Boxers Name		R3		0:02		NOC code Boxers Name			
Scores									
Warnings		Round:		R1	R2	R3			
2	1	Score:		6	7	4	6		

5.6 The following display will be shown immediately after the third round

Coach Online Scoreboard									
During Bout									
Ring A		52kg		Bout: 1					
NOC code Boxers Name		R3		0:00		NOC code Boxers Name			
Scores									
Warnings		Round:		R1	R2	R3			
2	1	Score:		6	7	4	6		

5.7 The following display will be shown immediately after the Referee declares the winner

Coach Online Scoreboard									
After Bout									
Ring A		Winner		Bout: 1					
NOC code 16		Blue		19		NOC code			
		Pts							
J1	J2	J3	J4	J5					
4	5	8	6	7	7	6	6	6	4
Scores									
Warnings		Round:		R1	R2	R3			
2	1	Score:		6	7	4	6	6	6

5.8 The following display will be shown in case the bout is stopped during any round

Coach Online Scoreboard									
After Bout									
Ring A		Winner		Bout: 1					
NOC code		Blue		RSC-I		NOC code			
J1	J2	J3	J4	J5					
Scores									
Warnings		Round:		R1	R2	R3			
2	1	Score:		6	7	4	6		

APPENDIX M

AIBA COACHES MANAGEMENT SYSTEM

1. COACHES CLASSIFICATION AND CERTIFICATION

- 1.1. The objectives of the new system are to develop long lasting qualified Coaches at all levels (national, continental and international). The comprehensive system for the AIBA Coaches Management System should be controlled centralized and therefore the quality and performance of Coaches at all levels will constantly improve. The new AIBA Coaches Management System is also to prevent that any unqualified Coach has an influence on the image and quality of the sport of boxing.

1.1.1. Coaches Qualifications Policy

- All AIBA Coaches must be certified by both their National Federation and AIBA
- AIBA Coaches can become WSB Coaches after having followed the WSB coaching program
- WSB Coaches may be AIBA Coaches without any restriction
- AIBA Coaches are also allowed to take positions in National Federations as elected members
- All Coaches active in WSB shall be allowed to participate in Olympic Games and Olympic Qualifying Events at all levels as well as to designated important competitions.

1.1.2. Coaches Performance Management - Coaches Evaluation

In order to become an AIBA classified Coach, a data form must be submitted to AIBA which will be evaluated by the AIBA Coaches Commission. Only data that is submitted by the National Federation will be taken into account. All Coaches data submitted by the National Federation will receive an official AIBA status. The evaluation will be according to the following criteria:

1.1.2.1. 3-Star Coach (who meets 3 out of 4 qualifications)

1.1.2.1.1. Current National Head Coach

1.1.2.1.2. Former National Head Coach (within 10 years)

1.1.2.1.3. A Coach who possess the highest national coaching school certificate

1.1.2.1.4. A Coach who has over 20 years coaching experience without any interruption

1.1.2.2. 2-Star Coach (who meets 2 out of 4 qualifications)

1.1.2.2.1. Current National Head Coach

1.1.2.2.2. Former National Head Coach (within 10 years)

1.1.2.2.3. A Coach who possess the highest or the second highest national coaching school certificate

1.1.2.2.4. A Coach who has over 20 years coaching experience without any interruption

Or, 2-Star Coach (who has the following qualifications)

1.1.2.2.5. Current National Assistant Coach

1.1.2.2.6. A Coach who possess the national coaching school certificate

1.1.2.2.7. A Coach who has over 10 years coaching experience without any interruption

1.1.2.3. 1-Star Coach (who meets 2 out of 3 qualifications)

1.1.2.3.1 Current National Trainer

1.1.2.3.2.A Coach who has over 5 years coaching experience without any interruption

1.1.2.3.3.A Coach who possess the national coaching school certificate.

1.1.3. Coaches In-Competition Management

1.1.3.1. For all AIBA 3-Star Events, each participating National Federation must have at least one 3-Star level Coach because only 3-Star Coaches are allowed in the position of Seconds. Each National Federation must have one mandatory 3-Star Coach along with another level Coach.

1.1.3.2. In the registration of the Team Delegation form, a copy of the 3-Star Coaches certification must be submit and Coaches will need to bring a valid AIBA ID card.

Also all registrations of 3-Star Events will be checked through the AIBA Database to make sure that the subscription is valid.

1.1.3.3 Until the new Coaches Management System is in place, a two years grace period is active until the end of December 2012 for all Coaches.

1.1.3.4. 1-Star level Coach:

1.1.3.4.1. All Coaches who are qualified up to national level and are active in National and AIBA 1-Star Events only

1.1.3.5. 2-Star level Coach:

1.1.3.5.1. All Coaches who are qualified up to national and international levels and are active in continental and AIBA 2-Star Events only

1.1.3.6. 3-Star level Coach:

1.1.3.6.1. All Coaches who are qualified as National Coaches and active in AIBA 3-Star Events.

1.1.4. Coaches Control Test

1.1.4.1. To ensure that Coaches remain active and updated to the AIBA Coaching Requirements, they have to be active at AIBA Approved Events which correspond to their Star status according to the frequency given below. If not, the Coaches will lose their Star status and an AIBA Coaches Control Test needs to be conducted.

1.1.4.1.1. 1-Star Coach: every 4 years

1.1.4.1.2. 2-Star Coach: every 3 years

1.1.4.1.3. 3-Star Coach: every 2 years

The validity period of the license will be extended for 2 to 4 years (depending on Star status) from the year of the tournament.

1.1.5. Coaches Database

- 1.1.5.1. All Coaches data forms submitted by National Federations will be registered in the AIBA Coaches Database. The National Federations are responsible to send the filled AIBA Coaches data forms to the AIBA HQ Office. All registered Coaches will receive an AIBA certification when being evaluated.

1.1.6. Coaches Academy Management

- 1.1.6.1. The AIBA Coaches Commission will not only evaluate the current level of the Coaches, it will also develop the training courses and examinations at all levels. This will allow all Coaches to follow the process of obtaining the right level of certification.
- 1.1.6.2. For graduation from a 2-Star Coach to a 3-Star Coach status, all courses and examinations will be organized by the AIBA Coaches Commission and will only take place at the AIBA Boxing Academy.
- 1.1.6.3. For graduation from a 1-Star Coach to a 2-Star Coach status, examinations will take place in each different region and will be done by the Academy Instructors and AIBA designated Examiners.
- 1.1.6.4. To obtain the 2-Star Coaches Certification, the Coaches data form must be submitted to the AIBA HQs Office and an evaluation by the AIBA Coaches Commission will determine the level following the criteria given.

1.1.7. WSB Coaches Management

- 1.1.7.1. There are no restrictions on AIBA Olympic-style boxing Coaches working as WSB Coaches and vice versa.
- 1.1.7.2. The same rules that apply to Seconds' eligibility in AIBA Olympic-style boxing apply to Seconds in WSB.

APPENDIX N DECLARATION OF NON PREGNANCY

1. DECLARATION OF NON PREGNANCY FOR WOMEN BOXERS AGED 18 (EIGHTEEN) AND OLDER

Date: _____

Place: _____

Name of Event: _____

I, _____, declare that I am not pregnant.

I understand the seriousness of this statement and accept full responsibility for it. In the event that this declaration is subsequently shown to be inaccurate or untrue and I suffer any related injury or damage during the Event, I on behalf of myself, my heirs, executors and administrators, waive and release any and all claims for damages I may have against AIBA (including its officials and employees), the organizers of the Event (including the Local Organizing Committee and/or the Host Federation) and the Competition Venue owners for such injury or damage.

Signature of the Boxer

2. DECLARATION OF NON PREGNANCY FOR GIRLS BOXERS AGED UNDER 18 (EIGHTEEN)

Date: _____

Place: _____

Name of Event: _____

I, _____, am one of the parents / legal caretaker of _____,

(insert name of the Boxer) and declare, on her behalf, that she is not pregnant.

I understand the seriousness of this statement and accept full responsibility for it. In the event that this declaration is subsequently shown to be inaccurate or untrue and _____,

(insert name of the Boxer) suffers any related injury or damage during the Event, I on behalf of _____, *(insert name of the Boxer)*, her heirs, executors and administrators,

waive and release any and all claims for damages she may have against AIBA (including its officials and employees), the organizers of the Event (including the Local Organizing Committee and the Host Federation) and the Competition Venue owners for such injury or damage.

Signature of one of the Parents / Legal Caretaker

Acknowledged by

[Signature of the Boxer]